

Stepper Motors

Technical Information

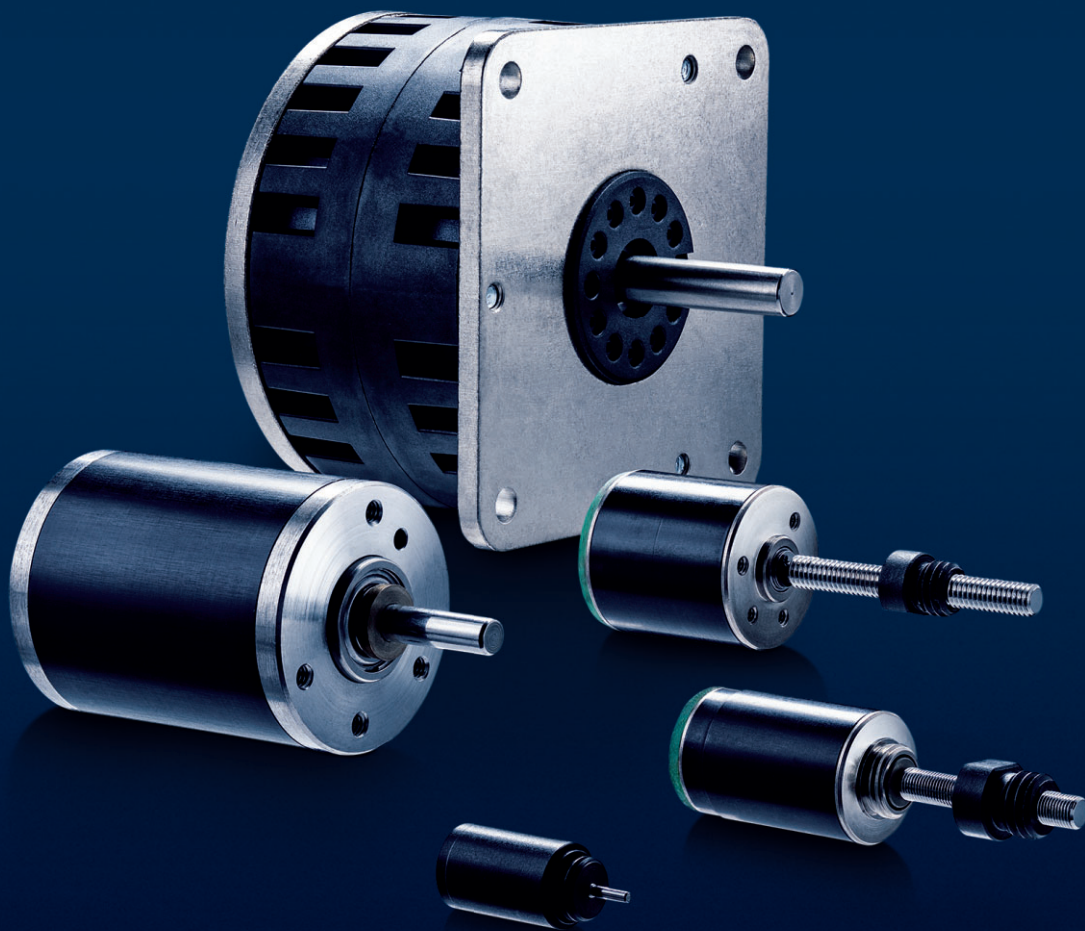

Stepper Motors

Technical Information

| Stepper Motors | |
|--|--------|
| Two phase with Disc Magnet, 20 steps per revolution | |
| Series DM0620 | |
| Values at 20°C | DM0620 |
| Nominal current per phase (both phases ON) | |
| Boosted current per phase (both phases ON) | |
| Nominal voltage per phase (both phases ON) | |
| Phase resistance | |
| Phase inductance (1 kHz) | |
| Holding torque (at nominal current) | |

Notes on technical datasheet

Nominal current per phase [A]

The current supplied to the motor phases that will not exceed, at an ambient temperature of 20 °C, the thermal limits of the motor.

Boosted current per phase [A]

Maximum current which can be supplied to the motor phases for a short period of time not to exceed the thermal capacity of the motor.

Nominal voltage per phase [V]

Voltage necessary to reach the nominal current per phase.

Phase resistance [Ω]

Winding resistance per phase. Tolerance +/- 12%, steady state.

Phase inductance [mH]

Winding inductance per phase measured at 1kHz.

Holding torque [mNm]

The torque generated by the motor at nominal current.

Holding torque at boosted current [mNm]

The torque the motor generates at boosted current. The magnetic circuit of the motor will not be affected by this boosted current, however, to avoid thermal overload the motor should only be boosted intermittently.

Residual torque, typ [mNm]

The typical torque applied to the shaft to rotate it without current to the motor. Residual torque is useful to hold a position without any current to save battery life or to reduce motor temperature.

Back-EMF amplitude [V/k step/s]

Amplitude of the back-EMF measured at 1000 steps/s.

Electrical time constant [ms]

Time needed to establish 63% of the max. possible phase current under a given operation point.

Rotor inertia [kgm²]

This value represents the inertia of the complete rotor.

Step angle (full step) [degree]

Number of angular degrees the motor moves per full-step.

Angular accuracy [% of full step]

The percentage position error per full step, at no load and nominal current. This error is not cumulative between steps.

Angular acceleration, max [rad/s²]

Maximum acceleration the motor can reach in boosted mode and without any load.

$$\alpha_{max} = \frac{M_{boosted}}{J}$$

Speed up to [min⁻¹]

The maximum recommended motor speed. Exceeding this speed could affect the motor integrity.

Resonance frequency (at no load) [Hz]

The step rate at which the motor at no load will demonstrate resonance. The resonance frequency is load dependent. For the best results the motor should be driven at a higher frequency or in half-step or microstepping mode outside of the given frequency.

$$f = \frac{1}{2\pi} \cdot \sqrt{\frac{M}{J}}$$

Thermal resistance [K/W]

R_{th1} corresponds to the value between the coil and the housing. R_{th2} corresponds to the value between the housing and the ambient air. R_{th2} can be reduced by enabling exchange of heat between the motor and the ambient air (for example using a heat sink or forced air cooling). If only one value is provided, R_{th} , it is the equivalent resistance between the coil and the air.

Thermal time constant [s]

The thermal time constant specifies the time needed for the winding respectively the housing to reach a temperature equal to 63% of the final steady state value.

Operating temperature range [°C]

Temperatures at which the motor can operate.

Winding temperature, max. [°C]

Maximum temperature supported by the windings and the magnets.

Shaft bearings

Self lubricating sintered sleeve bearings or preloaded ball bearings are available.

Stepper Motors

Technical Information

Shaft load max. [N]

The output shaft load at a specified shaft diameter for the front output shaft. For motors with ball bearings the load and lifetime are in accordance with the values given by the bearing manufacturers. This value does not apply to second, or rear shaft ends. In case of ball bearings, if the bearing preload is exceeded, reversible shaft displacement of $\sim 200\mu\text{m}$ may occur.

Shaft play max. [mm]

The play between the shaft and bearings.

Housing material

Material of the motor housing.

Mass [g]

Is the motor mass in grams.

Magnet material

The basic type of magnet used in the standard motor.

How to select a Stepper Motor

The selection of a stepper motor requires the use of published torque speed curves based on the load parameters.

It is not possible to verify the motor selection mathematically without the use of the curves.

To select a motor the following parameters must be known:

- Motion profile
- Load friction and inertia
- Required resolution
- Available space
- Available power supply voltage

1. Definition of the load parameters at the motor shaft

The target of this step is to determine a motion profile needed to move the motion angle in the given time frame and to calculate the motor torque over the entire cycle using the application load parameters such as friction and load inertia.

The motion and load profiles of the movement used in this example are shown below.

Depending on the motor size suitable for the application it is required to recompute the load parameters with the motor inertia as well.

In the present case it is assumed that a motor with an outside diameter of maximum 15 mm is suitable and the data has been computed with the inertia of the AM1524.

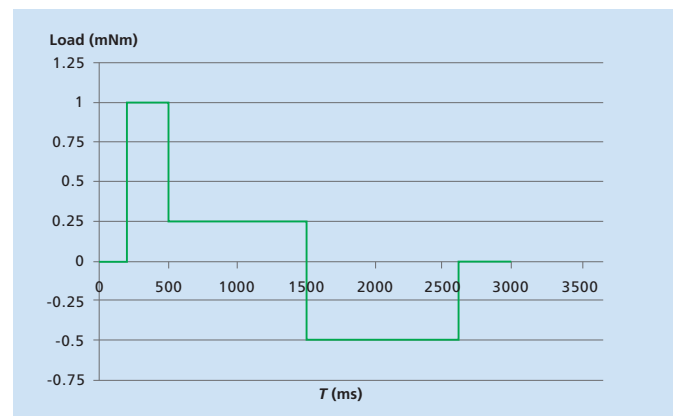
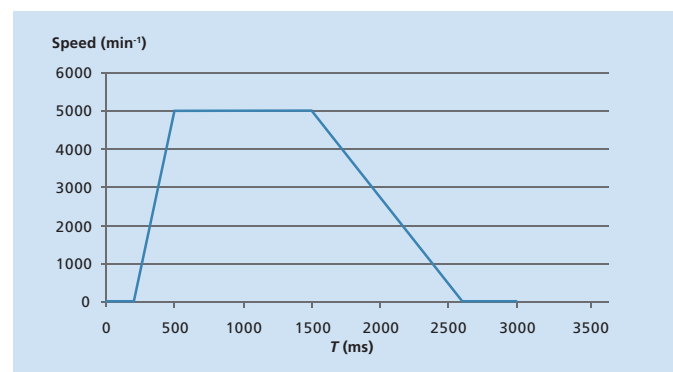

Stepper Motors

Technical Information

2. Verification of the motor operation.

The highest torque/speed point for this application is found at the end of the acceleration phase. The top speed is then $n = 5000 \text{ min}^{-1}$, the torque is $M = 1 \text{ mNm}$.

Using these parameters you can transfer the point into the torque speed curves of the motor as shown here with the AM1524 curves.

To ensure the proper operation of the motor in the application, it is highly recommended to use a design margin of 30% during the torque calculation. The shown example assures that the motor will correctly fulfil the requested application conditions.

The use of a higher supply voltage (typically 2.5 to 5 x higher than the nominal voltage) provides a higher torque at higher speed (please refer to the torque-speed curves).

In case no solution is found, it is possible to adapt the load parameters seen by the motor by the use of a reduction gearhead.

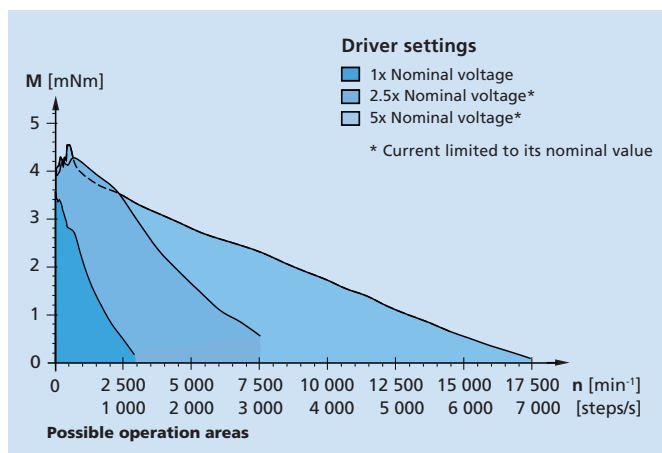

3. Verification of the resolution

It is assumed that the application requires a 9° angular resolution.

The motor selected, the AM1524, has a full step angle of 15° which is not suitable in full step mode. It can be operated either in half-step, or in microstepping. With microstepping, the resolution can be increased even higher but the angular accuracy is reduced because the error angle (expressed in % of a full-step) is independent from the number of microsteps.

For that reason the most common solution for adapting the motor resolution to the application requirements is the use of a gearhead or a lead-screw where linear motion is required.

4. Operation at low speed

All stepper motors exhibit a resonance frequency.

These are typically below 100Hz. When operating at this frequency stepper motors will exhibit uncontrolled perturbations in speed, direction of rotation and a reduced torque. Thus, if the application requires a speed lower or equal to the resonance frequency, it is recommended to drive the motor in microstepping mode where the higher the microstepping rate, the better performance can be achieved. This will greatly decrease the effects of the resonant frequency and result in smoother speed control.

5. Verification in the application

Any layout based on such considerations has to be verified in the final application under real conditions.

Please make sure that all load parameters are taken into account during this test.

Direction of rotation

All motors will rotate in CCW direction when using the following commutation sequence : 1.A+B+ 2.A-B+ 3.A-B- 4.A+B-. Only exception is the AM1524 which runs CW using here above commutation sequence.

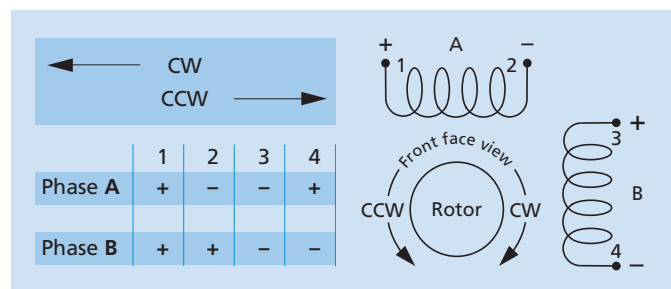

Stepper Motors

Technical Information

General application notes

In principle each stepper motor can be operated in three modes: full step (one or two phases on), half step or microstep.

Holding torque is the same for each mode as long as dissipated power (I^2R losses) is the same. The theory is best presented on a basic motor model with two phases and one pair of poles where mechanical and electrical angle are equal.

- In full step mode (1 phase on) the phases are successively energised in the following way:
1. A+ 2. B+ 3. A- 4. B-
- Half step mode is obtained by alternating between 1-phase-on and 2-phases-on, resulting in 8 half steps per electrical cycle: 1. A+ 2. A+B+ 3. B+ 4. A-B+ 5. A- 6. A-B- 7. B- 8. A+B-
- If every half step should generate the same holding torque, the current per phase is multiplied by $\sqrt{2}$ each time only 1 phase is energised.

The two major advantages provided by microstep operation are lower running noise and higher resolution, both depending on the number of microsteps per full step limited by the capability of the controller.

As explained above, one electrical cycle or revolution of the field vector (4 full steps) requires the driver to provide a number of distinct current values proportional to the number of microsteps per full step.

For example, 8 microsteps require 8 different values which in phase A would drop from full current to zero following the cosine function from 0° to 90° , and in phase B would rise from zero to full following the sine function.

These values are stored and called up by the program controlling the chopper driver. The rotor target position is determined by the vector sum of the torques generated in phase A and B:

$$M_A = k \cdot I_A = k \cdot I_o \cdot \cos \varphi$$

$$M_B = k \cdot I_B = k \cdot I_o \cdot \sin \varphi$$

where M is the motor torque, k is the torque constant and I_o the nominal phase current.

For the motor without load the position error is the same in full, half or microstep mode and depends on distortions of the sinusoidal motor torque function due to detent torque, saturation or construction details (hence on the actual rotor position), as well as on the accuracy of the phase current values.

Stepper Motors

Basic design

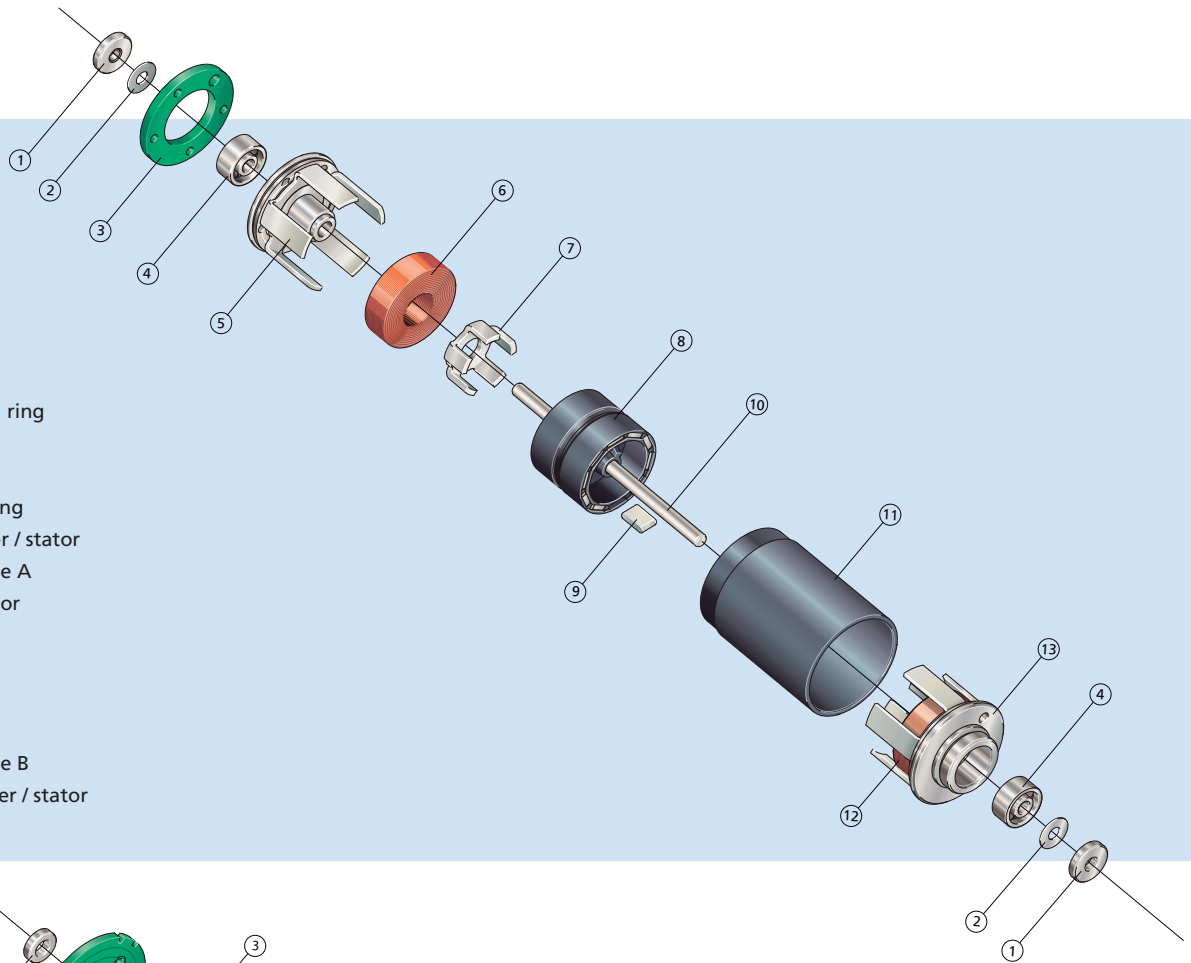

Two phase

- ① Retaining ring
- ② Washer
- ③ PCB
- ④ Ball bearing
- ⑤ Rear cover / stator
- ⑥ Coil, Phase A
- ⑦ Inner stator
- ⑧ Rotor
- ⑨ Magnets
- ⑩ Shaft
- ⑪ Housing
- ⑫ Coil, Phase B
- ⑬ Front cover / stator

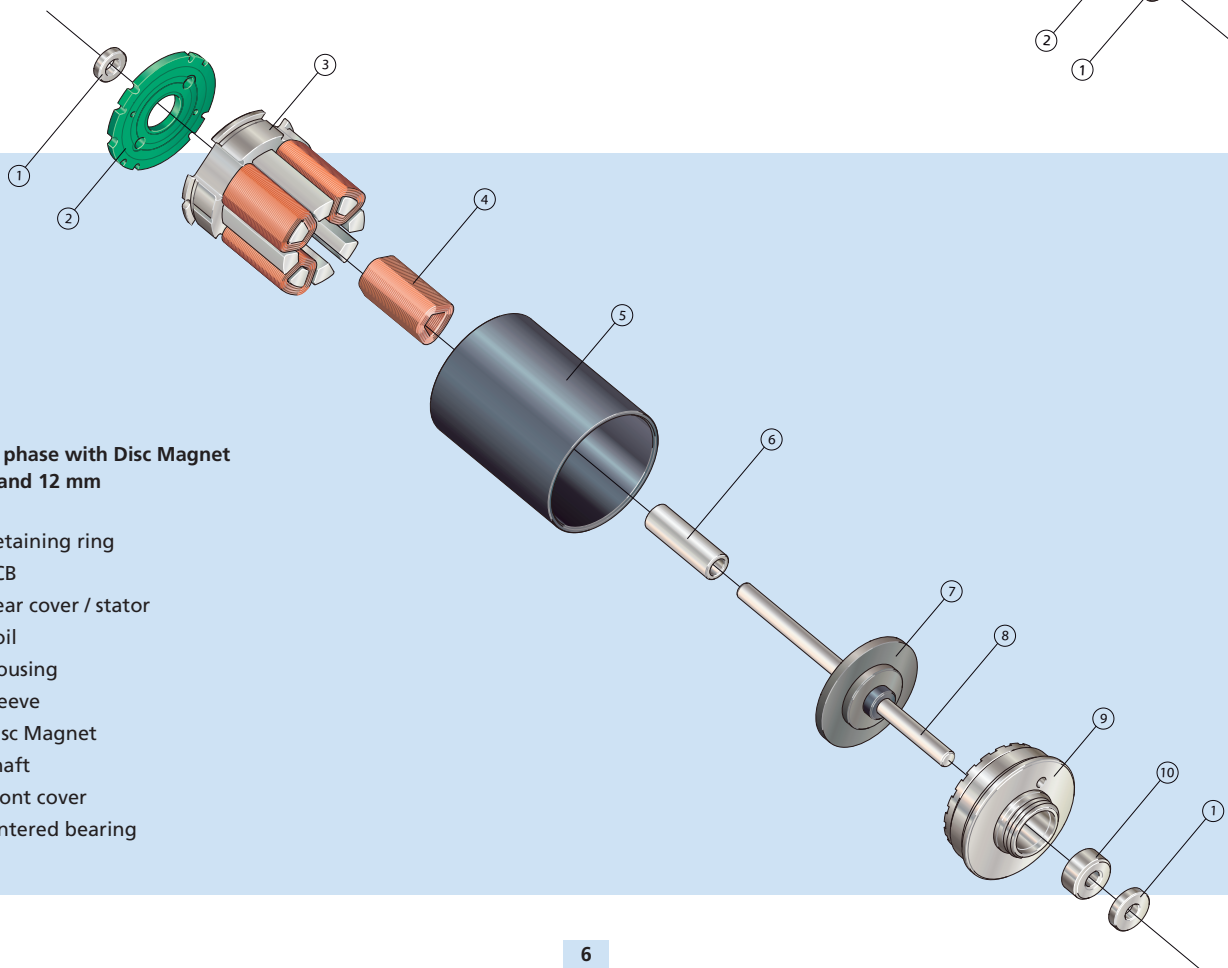

Two phase with Disc Magnet Ø 6 and 12 mm

- ① Retaining ring
- ② PCB
- ③ Rear cover / stator
- ④ Coil
- ⑤ Housing
- ⑥ Sleeve
- ⑦ Disc Magnet
- ⑧ Shaft
- ⑨ Front cover
- ⑩ Sintered bearing

Stepper Motors

Basic design

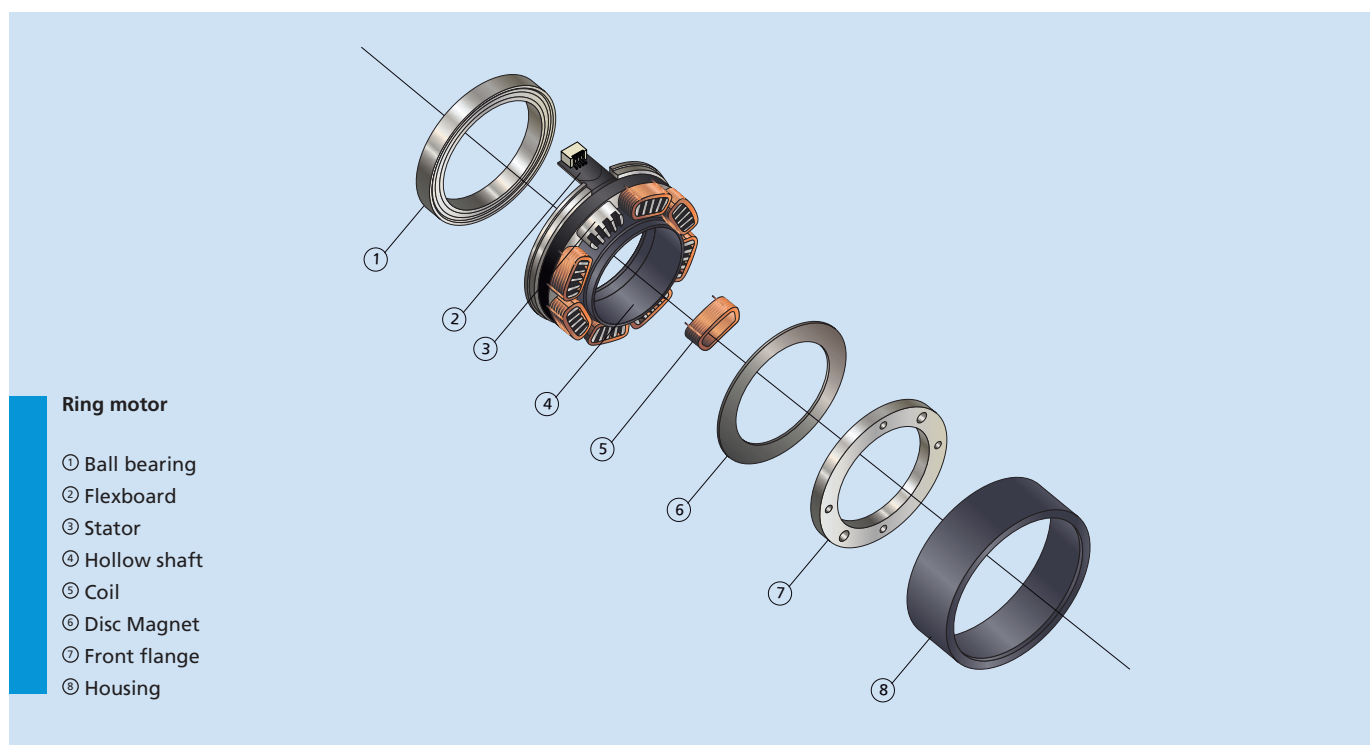
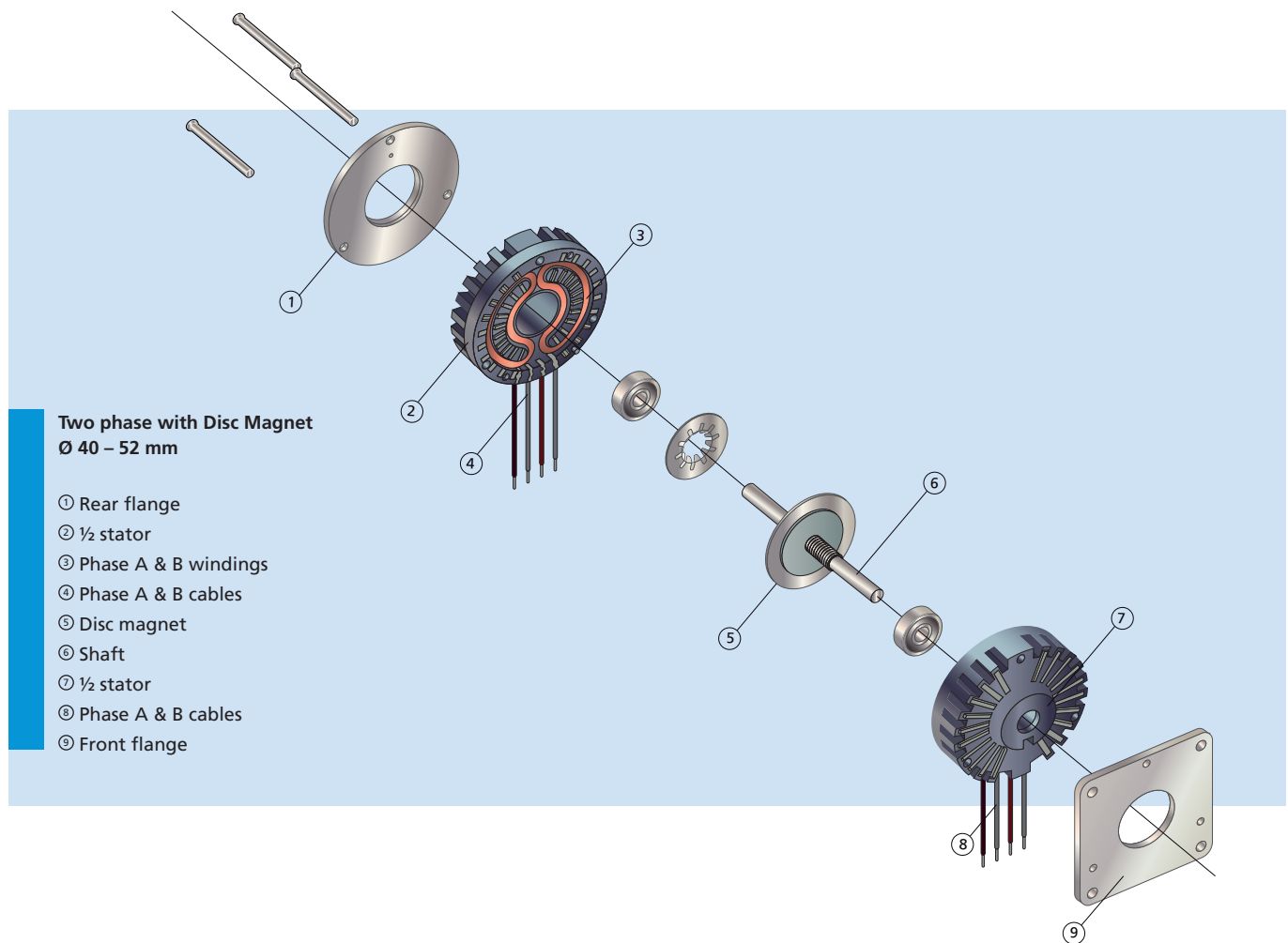

Stepper Motors – 2 phases permanent magnet Technology

The FAULHABER Stepper Motors are two phase multi-polar motors with permanent magnets. The use of rare-earth magnets provides an exceptionally high power to volume ratio. Their rotor design with very low inertia makes them ideally suited for applications requiring very fast acceleration or change of directions and allows to start from the first step with a given speed, reducing further time needed for the acceleration ramp. Their short length and light weight allow them to be used in highly integrated systems.

Thanks to a robust design they can be selected for the harshest environments. Precise, open-loop, speed and position control can be achieved with the application of full step, half step, or microstepping electronics.

The FAULHABER Stepper Motors can be combined with lead-screws or gearheads enabling to reach operational points that are today unmatched in the market.

Series

| | |
|--------|----------|
| DM0620 | AM2224R3 |
| AM0820 | DM40100R |
| AM1020 | DM52100S |
| DM1220 | DM52100R |
| AM1524 | DM52100N |
| AM2224 | DM66200H |

Key Features

| | |
|--------------------------------|-------------------------------|
| Outer diameter | 6 ... 66 mm |
| Motor length | 9,5 ... 32,6 mm |
| Number of steps per revolution | 20 / 24 / 100 / 200 |
| Holding torque (boost) | 0,25 (0,39) ... 307 (581) mNm |



DM 0620 2R 0080 11

Product Code

| | |
|-------------|-------------------------|
| DM | Motor design |
| 06 | Motor diameter [mm] |
| 20 | Steps per revolution |
| - | Version (if applicable) |
| 2R | Bearings |
| 0080 | Winding |
| 11 | Motor execution |

WE CREATE MOTION



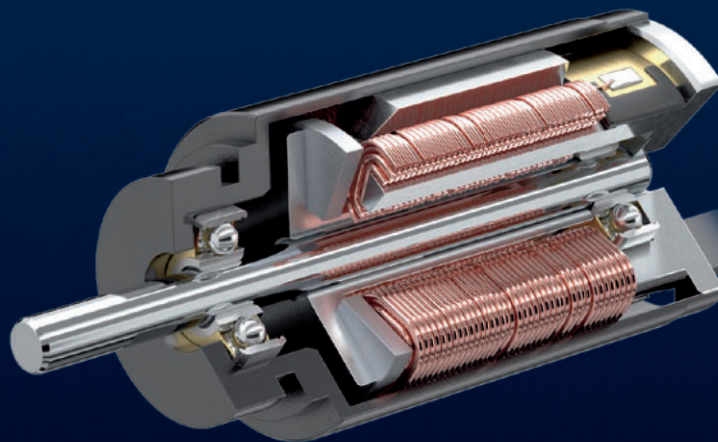

FAULHABER Stepper Motors

Advantages of this series at a glance

- Cost effective positioning drive without encoder
- High power density
- Very high acceleration
- Ultra-fast change of direction capability
- Long operational lifetimes
- Wide operational temperature range
- Speed range up to 16 000 min⁻¹ using a current mode chopper driver
- Possibility of full step, half step and microstep operation
- Extremely low rotor inertia



More information

-  [faulhaber.com](https://www.faulhaber.com)
-  [faulhaber.com/facebook](https://www.faulhaber.com/facebook)
-  [faulhaber.com/youtubeEN](https://www.faulhaber.com/youtubeEN)
-  [faulhaber.com/linkedin](https://www.faulhaber.com/linkedin)
-  [faulhaber.com/instagram](https://www.faulhaber.com/instagram)

As at:
17th edition, 2022

Copyright
by Dr. Fritz Faulhaber GmbH & Co. KG
Daimlerstr. 23 / 25 · 71101 Schönaich

All rights reserved, including translation rights. No part of this description may be duplicated, reproduced, stored in an information system or processed or transferred in any other form without prior express written permission of Dr. Fritz Faulhaber GmbH & Co. KG.

This document has been prepared with care. Dr. Fritz Faulhaber GmbH & Co. KG cannot accept any liability for any errors in this document or for the consequences of such errors. Equally, no liability can be accepted for direct or consequential damages resulting from improper use of the products.

Subject to modifications.

The respective current version of this document is available on FAULHABER's website: www.faulhaber.com