

EtherCAT – The Ethernet Fieldbus

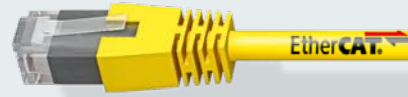

EtherCAT[®] 
Technology Group



3	A bus system might not be everything ...
4	EtherCAT at a glance
6	The EtherCAT Technology Group
8	Why use EtherCAT?
10	The technology in detail
10	EtherCAT: Based on Ethernet technology
11	How does EtherCAT work?
12	The EtherCAT protocol
14	Flexible topology
16	Distributed Clocks for high-precision synchronization
18	Diagnostics and error localization
19	Principle of EtherCAT MainDevice independent diagnostic interface
21	High availability requirements
22	EtherCAT G: Communication at gigabit levels
24	System overview
26	EtherCAT P: Communication and power in one cable
28	Safety over EtherCAT
30	Communication profiles
33	Plant-wide communication with the EtherCAT Automation Protocol (EAP)
35	Integration of other bus systems
36	Powering the digital transformation with EtherCAT, Industry 4.0 and IoT
38	Implementing EtherCAT interfaces
40	Implementing a MainDevice (MDevice)
42	Implementing a SubDevice (SDevice)
44	Conformance and certification
47	Contact

... but a machine is nothing without it!

It forms the core of the system architecture and its performance also determines whether the entire system is able to reach its full potential. The bus system is also a key factor in determining system costs, commissioning time, and robustness. A good engineer therefore selects the right bus technology first of all when designing a system.

We've written this brochure to introduce you to EtherCAT, the Ethernet fieldbus. Not only will you get to know EtherCAT – you will also learn what makes EtherCAT the

fastest Industrial Ethernet standard.

This brochure also presents the EtherCAT Technology Group (ETG), the world's largest fieldbus organization. Most importantly, we hope to convey why EtherCAT is the right choice for your application. If you have any questions, feel free to contact us. We're passionate about EtherCAT and look forward to hearing from you.

On behalf of the
EtherCAT Technology Group team,
Martin Rostan, Executive Director,
EtherCAT Technology Group



Martin Rostan, Executive Director,
EtherCAT Technology Group



The worldwide ETG team
at a global strategy meeting.

EtherCAT is a high-performance, low-cost, easy to use Industrial Ethernet technology with a flexible topology. It was introduced in 2003 and has been an international standard since 2007. The EtherCAT Technology Group promotes EtherCAT and is responsible for its continued development. EtherCAT is an open technology: anyone is allowed to implement or use it.

How it works

EtherCAT's key functional principle lies in how its nodes process Ethernet frames: each node reads the data addressed to it and writes its data back to the frame all while the frame is moving downstream. This improves bandwidth utilization (one frame per cycle is often sufficient for communication) while also eliminating the need for switches or hubs.

Network performance

The unique way EtherCAT processes frames makes it the fastest Industrial Ethernet technology; no other technology can top EtherCAT's bandwidth utilization or the performance it elicits.

Flexible topology

In addition to its speed, an EtherCAT network can support up to 65,535 devices without placing restrictions on their topology: line, bus, tree, star – or any combination thereof. Fast Ethernet physics allows two devices to be up to 100 m (330 ft) apart, and greater distance can be achieved with fiber optics. EtherCAT also has additional features that offer further topological flexibility, such as Hot Connect and Hot Swap for devices, and added redundancy through a ring topology.

Versatility

EtherCAT is suitable for both centralized and decentralized system architectures. It can support MainDevice-to-MainDevice, MainDevice-to-SubDevice and SubDevice-to-SubDevice communication as well as incorporate subordinate fieldbuses. At factory level, the EtherCAT Automation Protocol has communication covered – all with the existing infrastructure.

Simplicity

When compared to a classic fieldbus system, EtherCAT is the obvious choice: node addresses can be set automatically, there's no need for network tuning, and onboard diagnostics with fault localization make pinpointing errors a snap. Despite these advanced features, EtherCAT is also easier to use than Industrial Ethernet: there are no switches to configure, and no complicated handling of MAC or IP addresses is required.

Low-cost

EtherCAT delivers all of the advantages of Industrial Ethernet at fieldbus prices. How? Firstly, EtherCAT doesn't require any active infrastructure components.

The controlling device doesn't require a special interface card and the connected devices use highly integrated, cost-effective chips available from a variety of suppliers. Furthermore, there's no need for costly IT experts to commission or maintain the system.

Industrial Ethernet

EtherCAT also supports common internet technologies without jeopardizing the network's real-time capability. Its Ethernet over EtherCAT protocol transports FTP, HTTP, TCP/IP, etc.

Functional safety

Safety over EtherCAT is just like EtherCAT itself – lean and fast. Functional safety is built directly into the bus with options for both centralized and decentralized safety logic. Thanks to the Black Channel approach, it is also available for other bus systems.

Open technology

EtherCAT is an internationally standardized open technology, meaning anyone is free to use the technology in a compatible form. However, being an open technology doesn't mean that anyone can arbitrarily change EtherCAT to suit his or her needs. This would put an end to interoperability. The EtherCAT Technology Group, the world's largest fieldbus organization, is responsible for the further development of EtherCAT so it remains both open and interoperable.

Tried and tested

EtherCAT is currently in use across the globe in an unrivaled range of applications. EtherCAT is used in machine control, measurement equipment, medical devices, automobiles and mobile machines, and in innumerable embedded systems.

The EtherCAT Technology Group



ETG exhibition booths present the technology as well as the broad EtherCAT product range.



ETG holds regional member meetings on a regular basis.

The EtherCAT Technology Group keeps EtherCAT technology open for all potential users. It brings EtherCAT device manufacturers, technology providers, and users together to further the technology.

It provides multiple Technical Working Groups where experts carefully work on various specific aspects of EtherCAT. All of these activities are focused on one common goal: keeping EtherCAT stable and interoperable. That's why there is only a single version of EtherCAT, and not a new version each year.

The ETG holds multiple EtherCAT Plug Fests in Europe, Asia, and America each year. These events bring EtherCAT device developers together to test and ensure device interoperability. Using the official EtherCAT Conformance Test Tool, each manufacturer tests its EtherCAT devices for conformance prior to their release. The ETG awards the manufacturer a conformance certificate following a successful test in an accredited test lab.

The ETG also holds international seminars and workshops and represents EtherCAT at exhibitions throughout the globe. It also provides product guides, joint exhibition booths, and seminar exhibits to help its members market their EtherCAT products.

The ETG has the largest number of members out of any fieldbus organization in the world. The list of members can be found on the ETG's homepage. However, the crucial factor is not how many members there are, but how active the members are in the ETG. Both the number and variety of EtherCAT devices are unparalleled, and EtherCAT's adoption rate across the globe is outstanding.

Become a member

ETG membership is open to all companies, whether they be device manufacturers or users.

ETG members:

- receive access to technical specifications and the developer's forum
- contribute to the further development of EtherCAT in the way of Technical Working Groups
- receive implementation support from their local ETG office
- receive free software stacks, software tools, and access to additional development products
- are permitted to use the EtherCAT and ETG logos
- display their EtherCAT products and services in the official EtherCAT Product Guide, exhibitions, and at ETG events.

Bylaws, the registration form, and additional information are available via info@ethercat.org and www.ethercat.org

International standardization

The EtherCAT Technology Group is an official partner of the IEC. Both EtherCAT and Safety over EtherCAT are IEC standards (IEC 61158 and IEC 61784). These standards not only include the lower protocol layers, but also the application layer and device profiles, e.g. for drives. SEMI™ (Semiconductor Equipment and Materials International) has accepted EtherCAT as a communication standard (E54.20) for the semiconductor industry. The various task groups in the ETG Semiconductor Technical Working Group (TWG) have defined industry-specific device profiles and implementation guidelines.

The EtherCAT specification is available in English, Japanese, Korean, and Chinese.

Global activities

The EtherCAT Technology Group is active worldwide. Experts in the ETG offices in Germany, China, Japan, Korea, and the USA support ETG members before, during, and after implementation.

The technology is maintained in several Technical Working Groups (TWG), which define enhancements and also homogenize device behavior via device profiles and implementation guidelines. All members are encouraged to actively contribute to the TWGs.



EtherCAT is also a national standard in many countries, such as Korea and China.

EtherCAT milestones



Why use EtherCAT?

EtherCAT

The unique way that EtherCAT works makes it the engineer's choice. The following features are particularly advantageous for certain applications.

1. Exceptional performance

EtherCAT is by and large the fastest Industrial Ethernet technology, but it also synchronizes with nanosecond accuracy.

This is a huge benefit for all applications in which the target system is controlled or measured via the bus system. The rapid reaction times reduce the wait times during transitions between process steps, which significantly improves application efficiency. Lastly, the EtherCAT system architecture typically reduces the load on the CPU by 25–30% in comparison to other bus systems (given the same cycle time). When optimally applied, EtherCAT's performance leads to improved accuracy, greater throughput, and thus to lowered costs.

2. Flexible topology

In EtherCAT applications, the machine structure determines the network topology, not the other way around. In conventional Industrial Ethernet systems, there are limitations on how many switches and hubs can be cascaded, which places limits on the overall network topology. Since EtherCAT doesn't need hubs or switches, there are no limitations. In short, EtherCAT is virtually limitless when it comes to network topology. You can create line, tree, star topologies and any combinations thereof with a nearly unlimited number of nodes. Thanks to automatic link detection,

nodes and network segments can be disconnected during operation and then reconnected, even in another position if required. Line topology is extended to a ring topology to assure cable redundancy. All the controlling device needs for this redundancy is a second Ethernet port, and the connected devices will then support cable redundancy. This means that devices can be switched out during machine operation.

3. Simple and robust

Configuration, diagnostics, and maintenance are all factors that contribute to system costs. The Ethernet fieldbus makes all of these tasks significantly easier: EtherCAT can be set to automatically assign addresses, which eliminates manual configuration. A low bus load and peer-to-peer physics improve electromagnetic noise immunity. The network reliably detects potential disturbances down to their exact location, which makes troubleshooting far faster. During startup, the network compares the planned and actual layouts to detect any discrepancies. EtherCAT performance also helps during system configuration by eliminating the need for network tuning. Thanks to the large bandwidth, additional TCP/IP can be transmitted together with the control data. However, since EtherCAT itself isn't based on TCP/IP, there is no need to administer MAC addresses or IP addresses or to have IT experts configure switches and routers.

4. Integrated safety

Functional safety is integrated into the network architecture with FailSafe over EtherCAT (FSoE). FSoE has proven itself in practice as it is used in TÜV certified devices that have been on the market since 2005. The protocol fulfills the requirements for SIL 3 systems and is suitable for both centralized and decentralized control systems. Thanks to the Black Channel approach and the incredibly lean safety container, FSoE can also be used in other bus systems. This integrated approach and the lean protocol help keep system costs down. Additionally, a non-safety-critical controller can also receive and process safety data.

5. Affordability

EtherCAT delivers the features of Industrial Ethernet at a price similar to or even below that for a classic fieldbus system. The only hardware required by the MainDevice is an Ethernet port – no expensive interface cards or co-processors are necessary. EtherCAT SubDevice Controllers are available from various manufacturers in different formats: as an ASIC, based on FPGA, or as an option for a standard microprocessor series. Since these inexpensive controllers shoulder all the time-critical tasks, EtherCAT itself doesn't place any performance requirements on the CPU of field devices, which keeps device costs down. EtherCAT doesn't require switches or other active infrastructure components, so the costs for these components and their installation, configuration, and maintenance are also eliminated.

For these reasons, EtherCAT is often seen in:

- robotics
- machine tools
- packaging machinery
- printing presses
- plastic manufacturing equipment
- presses
- semiconductor manufacturing machines
- test benches
- pick and place machinery
- measurement systems
- power plants
- substations
- material handling applications
- baggage handling systems
- stage control systems
- automated assembly systems
- pulp and paper machinery
- tunnel control systems
- welding machinery
- cranes and lifts
- farm machinery
- offshore applications
- sawmills
- window manufacturing equipment
- building automation systems
- iron and steelworks
- wind turbines
- furniture manufacturing equipment
- milling machinery
- automated guided vehicles
- entertainment automation
- medical devices
- woodworking machinery
- flat glass manufacturing equipment
- weighing systems
- and many more



The technology in detail

EtherCAT: Based on Ethernet technology

EtherCAT is Industrial Ethernet and utilizes standard frames and the physical layer as defined in the Ethernet Standard IEEE 802.3. However, it also addresses the specific demands faced in the automation industry, where:

- there are hardline real-time requirements with deterministic response times
- the system is usually made up of many nodes, and each node only has a small amount of cyclic process data
- hardware costs play an even bigger role here than they do in IT and office applications.

The above requirements make it practically impossible to use a standard Ethernet network at field level. If an individual Ethernet datagram is used for each node, the effective data rate sinks significantly for just a few bytes of cyclic process data: the shortest Ethernet datagram is 84 bytes long (including the interpacket gap), of which 46 bytes can be used for process data. For example, if a drive sends 4 bytes of process data for the actual position and status information and receives 4 bytes of data for the target position and control information, the effective data rate for both datagrams sinks to $4/84 = 4.8\%$. Additionally, the drive usually has a reaction time that triggers the transmission of the actual values after the target values have been received. At the end, not much of the 100 Mb/s transfer rate remains.

Protocol stacks, such as those used in the IT world for routing (IP) connection (TCP), require additional overhead for each node and create further delays through the stack runtimes.

How does EtherCAT work?

EtherCAT overcomes the difficulties described in the previous section with its high-performing mode of operation, in which a single frame is usually sufficient to send and receive control data to and from all nodes!

The EtherCAT MainDevice sends a datagram that passes through each node. Each EtherCAT field device reads the data addressed to it on the fly and inserts its data into the frame as the frame is moving downstream. The frame is only delayed by hardware propagation delay times. The last node in a segment or drop line detects an open port and sends the message back to the MainDevice using Ethernet technology's full duplex feature.

The datagram's maximum effective data rate increases to over 90%, and, due to the utilization of the full duplex feature, the theoretical effective data rate is even greater than 100 Mb/s.

The EtherCAT MainDevice is the only node within a segment allowed to actively send an EtherCAT frame; all other nodes merely forward frames downstream. This concept prevents unpredictable delays and guarantees real-time capability.

The control unit uses a standard Ethernet Media Access Controller (MAC) without an additional communication processor. This allows a MainDevice to be implemented on any hardware platform with an available Ethernet port, regardless of which real-time operating system or application software is used.

EtherCAT field devices use an EtherCAT SubDevice Controller (ESC) to process frames on the fly and entirely in the hardware, making network performance predictable and independent of the individual SubDevice implementation.



The EtherCAT protocol

EtherCAT embeds its payload in a standard Ethernet frame. The EtherCAT frame is identified by the identifier (0x88A4) in the EtherType field. Since the EtherCAT protocol is optimized for short cyclic process data, bulky protocol stacks, such as TCP/IP or UDP/IP, can be eliminated.

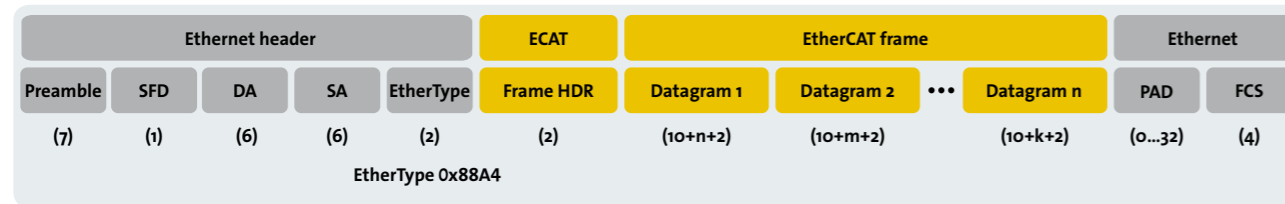

EtherCAT in a standard Ethernet frame (according to IEEE 802.3)

To ensure Ethernet IT communication between the nodes, TCP/IP connections can also be tunneled through a mailbox channel without impacting real-time data transfer.

During startup, the control unit configures and maps the process data on the connected devices. Different amounts of data can be exchanged with each node, from one bit to a few bytes, or even up to kilobytes of data.

The EtherCAT frame contains the frame header and one or more datagrams. The datagram header indicates what type of access the MainDevice would like to execute:

- read, write, or read-write
- access to a specific field device through direct addressing, or access to multiple field devices through logical addressing (implicit addressing).

Logical addressing is used for the cyclical exchange of process data. Each datagram addresses a specific part of the process image in the EtherCAT segment, for which 4 GB of address space is available. During network startup, each node is assigned one or more addresses in this global address space. If multiple nodes are assigned addresses in the same area, they can all be addressed with a single datagram. Since the datagrams contain all the data access related information in full, the MainDevice can decide when and which data to access. For example, the MainDevice can use short cycle times to refresh data on the drives, while using a longer cycle time to sample the I/O; a fixed process data structure is not necessary. This also relieves the controlling device in comparison to conventional fieldbus systems, in which

the data from each node has to be read individually, sorted with the help of the process controller, and copied into memory. With EtherCAT, the control device only needs to fill a single EtherCAT frame with new output data, and send the frame to the MAC controller via automatic direct memory access (DMA). When a frame with new input data is received via the MAC controller, the control unit can copy the frame into the computer's memory via DMA – all without the CPU having to actively copy any data.

In addition to cyclical data, further datagrams can be used for asynchronous or event-driven communication.

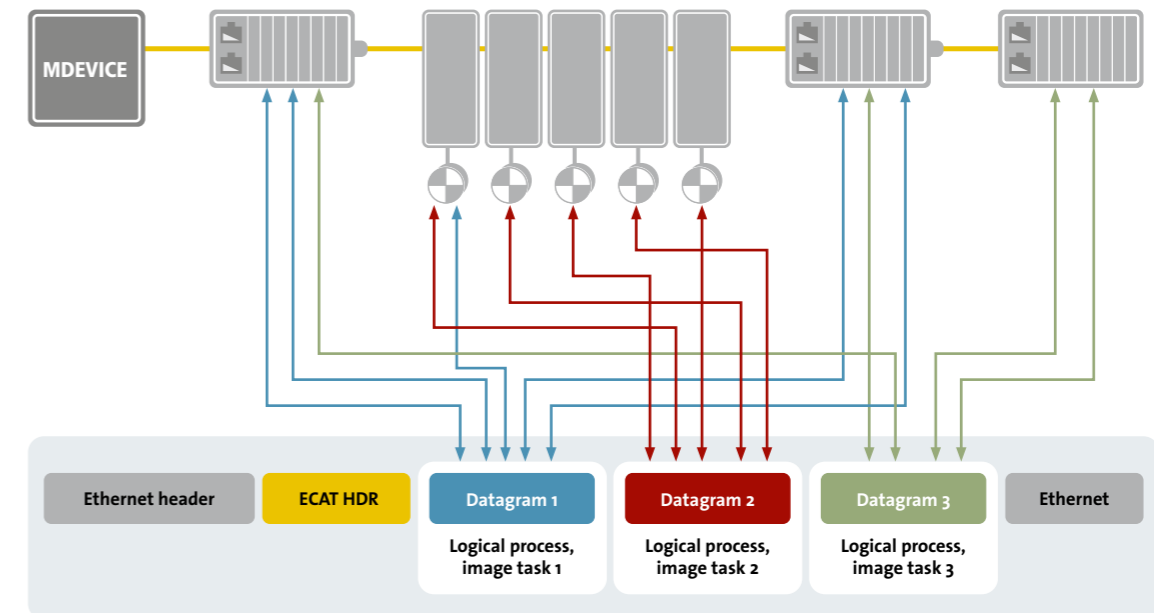

Inserting process data on the fly

In addition to logical addressing, the control unit can also address a field device via its position in the network. This method is used during network boot-up to determine the network topology and compare it to the planned topology.

After checking the network configuration, the MainDevice can assign each node a configured node address and communicate with the node via this fixed address. This enables targeted access to devices, even when the network topology is changed during operation, for example with Hot Connect groups. There are two approaches for SubDevice-to-SubDevice communication. A SubDevice can send data directly to another node that is connected further downstream in the network. Since EtherCAT frames

can only be processed going forward, this type of direct communication depends on the network's topology, and is particularly suitable for high-speed SubDevice-to-SubDevice communication in a fixed machine design (e.g. in printing or packaging machines). In contrast, freely configurable SubDevice-to-SubDevice communication runs through the control device and requires two bus cycles (but not necessarily two control cycles). Thanks to EtherCAT's excellent performance, this type of SubDevice-to-SubDevice communication is still faster than that of other communication technologies.

Flexible topology

Line, tree, star, or daisy-chain: EtherCAT supports almost all topologies. With EtherCAT, you can create a pure bus or line topology with hundreds of nodes without the limitations that normally arise from cascading switches or hubs.

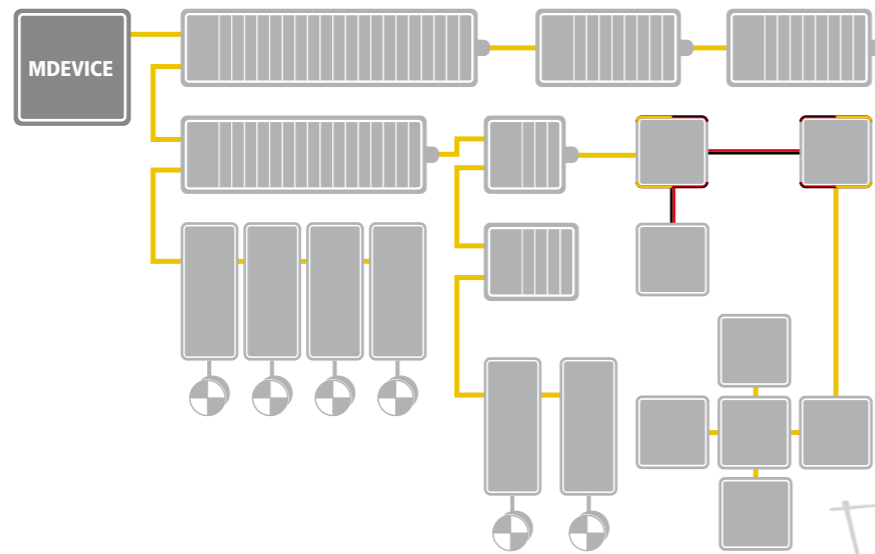

Flexible topology: line, tree, star, or daisy-chain

When wiring the system, the combination of lines with drop lines is particularly beneficial: the ports required to create drop lines are directly integrated in many I/O modules, so no additional switches or active infrastructure components are required. The star topology, the Ethernet classic, can also be utilized.

Modular machines or tool changers require network segments or individual nodes to be connected and disconnected during operation. EtherCAT SubDevice Controllers already include the basis for this Hot Connect feature. If a neighboring station is removed, then the port is automatically closed so the rest of the network can continue to operate without interference. Very short detection times of under 15 microseconds guarantee a smooth changeover.

EtherCAT offers a lot of flexibility regarding cable types, so each segment can use the exact type of cable that best meets its needs. Inexpensive Industrial Ethernet cables can be used between two nodes up to 100 m apart in 100BASE-TX mode. Furthermore, the EtherCAT P technology enables data and power to be transmitted via one cable. This option enables devices such as sensors to be connected with a single line. Optical fibers (such as 100BASE-FX) can also be used, for example for a node distance greater than 100 m. The complete range of Ethernet wiring is also available for EtherCAT.

Up to 65,535 devices can be connected to one EtherCAT segment, so network expansion is virtually unlimited. As a practically unlimited number of nodes are available, modular devices such as sliced I/O stations can be designed so that each module is an EtherCAT node of its own. The local extension bus is thus eliminated; the high performance of EtherCAT reaches each module directly and without any delays since there is no gateway in the bus coupler or head station anymore.

Distributed Clocks for high-precision synchronization

In applications with spatially distributed processes that require simultaneous action, precise synchronization is particularly important. For example, this is the case for applications in which multiple servo axes execute coordinated movements.

In contrast to completely synchronous communication, where communication errors have an immediate impact on quality, distributed synchronized clocks have a high degree of tolerance for jitter in the communication system. Therefore, the EtherCAT solution for synchronizing nodes is based on these distributed clocks (DC).

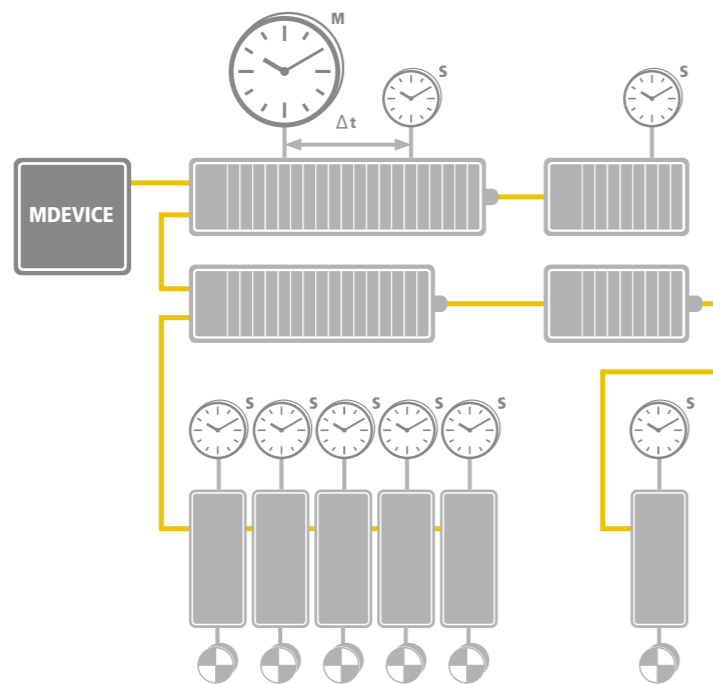

Completely hardware-based synchronization with compensation for propagation delays

The calibration of the clocks in the nodes is completely hardware-based. The time from the first DC SubDevice is cyclically distributed to all other devices in the system. With this mechanism, the field device clocks can be precisely adjusted to this reference clock. The resulting jitter in the system is significantly less than 1 μ s.

Since the time sent from the reference clock arrives at the field devices with a slight delay, this propagation delay must be measured and compensated for in each field device in order to ensure synchronicity and simultaneousness. This delay is measured during network startup or, if desired, continuously during operation, ensuring that the clocks are simultaneous with each other at within much less than 1 μ s.

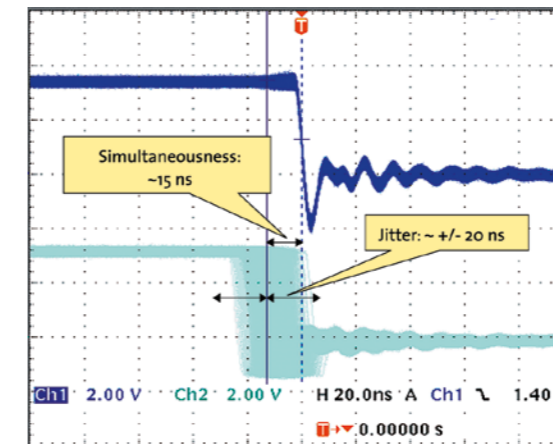

Synchronicity and simultaneousness
– scope view of two distributed devices with 300 nodes and 120 m cable length

If all nodes have the same time information, they can set their output signals simultaneously and affix their input signals with a highly precise timestamp. In motion control applications, cycle accuracy is also important, along with synchronicity and simultaneousness. In such applications, velocity is typically derived from the measured position, so it is critical that the position measurements are taken precisely equidistantly (i.e. in exact cycles). Even very small inaccuracies in the position measurement timing can translate to larger inaccuracies in the calculated velocity, especially in relation to short cycle times. With EtherCAT, the position measurements are triggered by the precise local clock and not the bus system, leading to far greater accuracy.

Furthermore, the use of Distributed Clocks also frees up the control unit; since actions such as position measurement are triggered by the local clock instead of when the frame is received, the requirements for sending frames are less strict for the control unit. This allows the MainDevice stack to be implemented in software on standard Ethernet hardware. Even jitter in the range of several microseconds does not diminish the accuracy of the Distributed Clocks! Since the accuracy of the clock does not depend on when it's set, the frame's absolute transmission time becomes irrelevant. The EtherCAT MainDevice only needs to ensure that the EtherCAT frame is sent early enough, before the DC signal in the nodes triggers the output.

Diagnostics and error localization

Experience with conventional fieldbus systems has shown that diagnostic characteristics play a major role in determining a machine's availability and commissioning time. In addition to error detection, error localization is important during troubleshooting. EtherCAT allows you to scan and compare the actual network topology with the planned topology during boot-up. EtherCAT also has many additional diagnostic capabilities inherent to its system.

The EtherCAT SubDevice Controller in each node uses a checksum to scan the moving frame for errors. Information is only provided to the SubDevice application if the frame has been received correctly. If there is a bit error, the error counter is incremented and the subsequent nodes are informed that the frame contains an error. The control unit will also detect that the frame is faulty and discard its information. The control unit is able to detect where the fault originally occurred in the system by analyzing the nodes' error counters. This is an enormous advantage in comparison to conventional fieldbus systems, in which an error is propagated along the entire party line, making it impossible to localize the source of the error. EtherCAT can detect and localize occasional disturbances before the issue impacts the machine's operation.

Thanks to EtherCAT's unique principle of bandwidth utilization, which is far better than Industrial Ethernet technologies that use single frames, the likelihood of bit errors induced by disturbances within an EtherCAT frame is substantially lower if the same cycle time is used.

If, in typical EtherCAT fashion, much shorter cycle times are used, the time required for error recovery is significantly reduced. Thus, it is also much simpler to resolve these issues within the application.

Within the frames, the working counter (WC) enables the information in each datagram to be monitored for consistency. Every node that is addressed by the datagram and whose memory is accessible increments the working counter automatically. The control is then able to cyclically confirm whether all nodes are working with consistent data. If the working counter has a different value than it should, the MainDevice does not forward this datagram's data to the control application. The MainDevice is then able to automatically detect the reason for the unexpected behavior with help from status and error information from the nodes as well as the link status.

Since EtherCAT utilizes standard Ethernet frames, Ethernet network traffic can be recorded with the help of free Ethernet software tools. For example, the well-known Wireshark software comes with a protocol interpreter for EtherCAT, so that protocol-specific information, such as the working counter, commandos, etc. are shown in plain text.

Further information on diagnostics can be found here: www.ethercat.org/diag

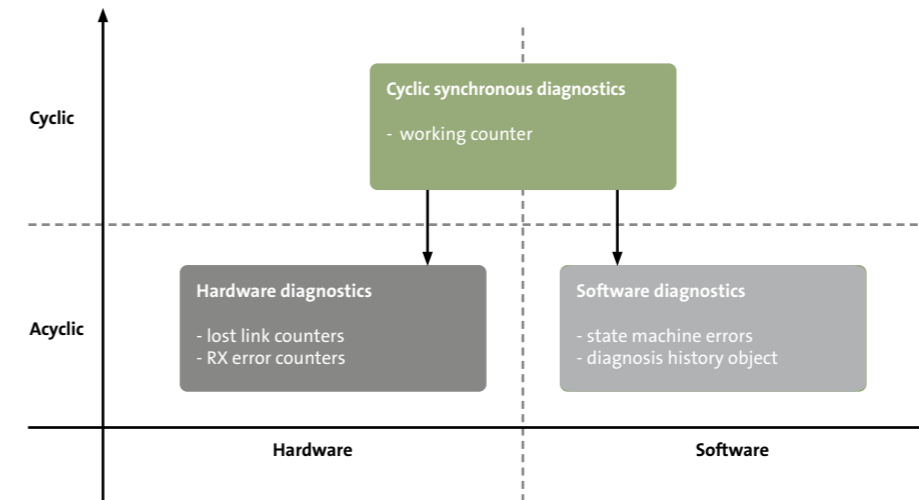

Summary of EtherCAT diagnostic functionalities

Principle of vendor-independent diagnostic interface

These functionalities provide all of the necessary diagnostic information for monitoring the network state and detecting and locating errors on the MainDevice in all EtherCAT networks.

This raw information also needs to be provided to diagnostic tools and to end users in order to be interpreted and used. With the ETG.1510 specification, the ETG has defined a solution which enables external tools to access the diagnostic information provided by EtherCAT networks in a way that is independent from the specific MainDevice vendor and software implementation.

The ETG.1510 profile enhances the ETG.1500 specification and extends the object dictionary of the EtherCAT MainDevice defined in ETG.5001.3 Annex A. The diagnostic objects can be read by the CAN application protocol over EtherCAT (CoE) mailbox protocol using the already specified mailbox gateway functionality. As it is fully based on existing standards, the new profile only requires a few elements in the object dictionary of the MainDevice. Both the network structure as expected by the MainDevice based on the offline configuration and the current network topology as detected by an online scan are provided. The diagnostic information itself is mapped in the form of consistent, cumulative counters that summarize the network state from its start up to the present. As a result, the diagnostic interface can be accessed at a frequency that is independent from the cycle time of the EtherCAT network, and realtime performance is not required in the external tools.

The diagnostic information is accessed via the well-established CAN application protocol over EtherCAT (CoE). Based on already existing and fully standard protocols and functionalities, this diagnostic interface can easily be implemented as a lean software extension on top of any standard MainDevice implementation. The amount of resources required by such a software extension is very small, which makes implementation of the diagnostic interface feasible for all MainDevice solutions, including simple and compact embedded systems.

Using the EtherCAT diagnostic interface, providers of machine and network diagnostic tools can use a general purpose, universal interface to collect diagnostic data from EtherCAT networks. They are able to report this information to technicians and engineers in a user friendly, graphically intuitive way. The networks do not need to change their behavior to fit the specific MainDevice manufacturer nor use a vendor's proprietary access protocol for each different MainDevice implementation.

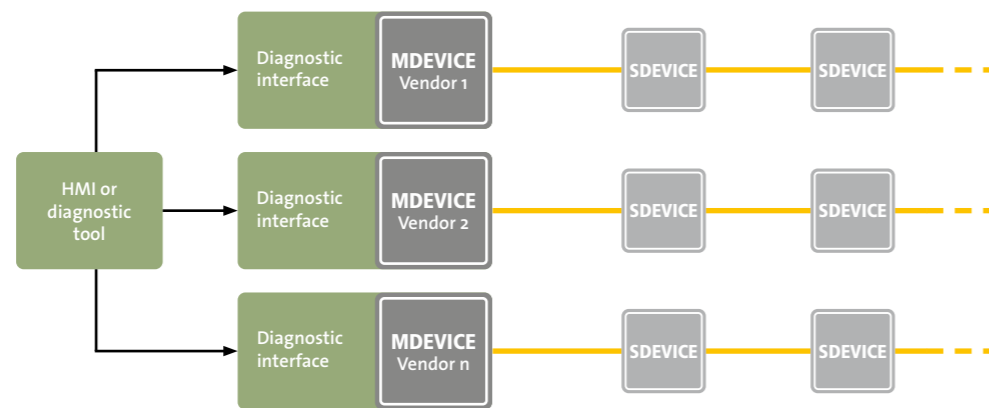

The diagnostic interface enables vendor-independent access to EtherCAT diagnostic data

High availability requirements

For machines or equipment with very high availability requirements, a cable break or a malfunctioning node should not mean that a network segment is no longer accessible, or that the entire network fails.

EtherCAT enables cable redundancy via simplicity. A cable from the last node can be connected to an additional Ethernet port in the MainDevice to transform a line topology is extended into a ring topology. A redundancy case, such as a cable break or a node malfunction, is detected by a software add-on in the MainDevice stack. That's all there is to it! The nodes themselves don't need to be modified, and don't even know that they're being operated in a redundant network.

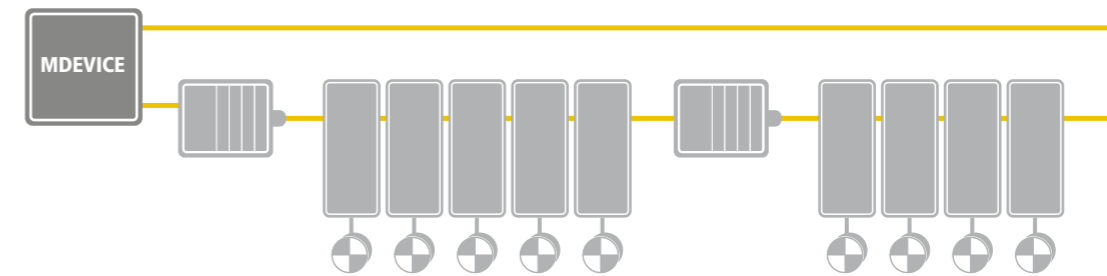

Inexpensive cable redundancy with standard EtherCAT field devices

Link detection in the connected devices automatically detects and resolves redundancy cases with a recovery time of less than 15 microseconds, so that only a single communication cycle is disrupted at maximum. This means that even motion applications with very short cycle times can continue working smoothly when a cable breaks.

With EtherCAT, MainDevice redundancy with hot standby can also be achieved. Vulnerable network components, such as those connected with a drag chain, can be wired with a drop line, so that even when a cable breaks, the rest of the machine keeps running.

EtherCAT G: Communication at gigabit levels



EtherCAT G is an extension of the standard EtherCAT protocol that enables data communication at rates of 1 Gb/s up to 10 Gb/s. This is particularly useful when transmitting large amounts of process data per network participant, as is the case with machine vision, high-end measurement technology or in complex motion applications.

The EtherCAT protocol itself, along with its positive features, are fully retained in EtherCAT G/G10. EtherCAT G/G10 is fully compatible with the IEEE 802.3 standard and the topology flexibility that it provides is also identical: drop lines, lines, daisy chains or tree structures can all be created.

A central element of EtherCAT G is the branch concept. It is achieved with an EtherCAT Branch Controller (EBC), which essentially fulfills two main functions:

- it acts as a kind of node for the integration of independent segments with 100 Mb/s devices
- it enables parallel processing of the connected EtherCAT segments.

As a result, the propagation delay is significantly reduced, which increases system performance many times over previous levels.

The data is forwarded into the single segments under priority and/or time control, with each branch treated like an independent EtherCAT segment: the frame doesn't run through all segments in series; instead, the segments are processed in parallel. This reduces propagation times in large networks significantly and increases the system performance many times over.

With the branch concept, even big plants can be managed from one central control unit. In typical EtherCAT fashion, the configuration of the EtherCAT Branch Controllers is managed via the MainDevice, so no additional configuration tools are needed. The MainDevice only has to have an appropriate Gb/s port. Important features such as diagnostics or network synchronization via Distributed Clocks are supported by the EBCs and are forwarded into the connected segments transparently.

EtherCAT G/G10 thus taps into the advantages of significantly increased bandwidth and reduced propagation times without the field devices themselves having to be equipped with gigabit interfaces: the tried and tested 100 Mb/s devices are retained and, through the EtherCAT Branch Controller concept, still benefit from the technology expansion. This means that EtherCAT is ready to meet more stringent future requirements.

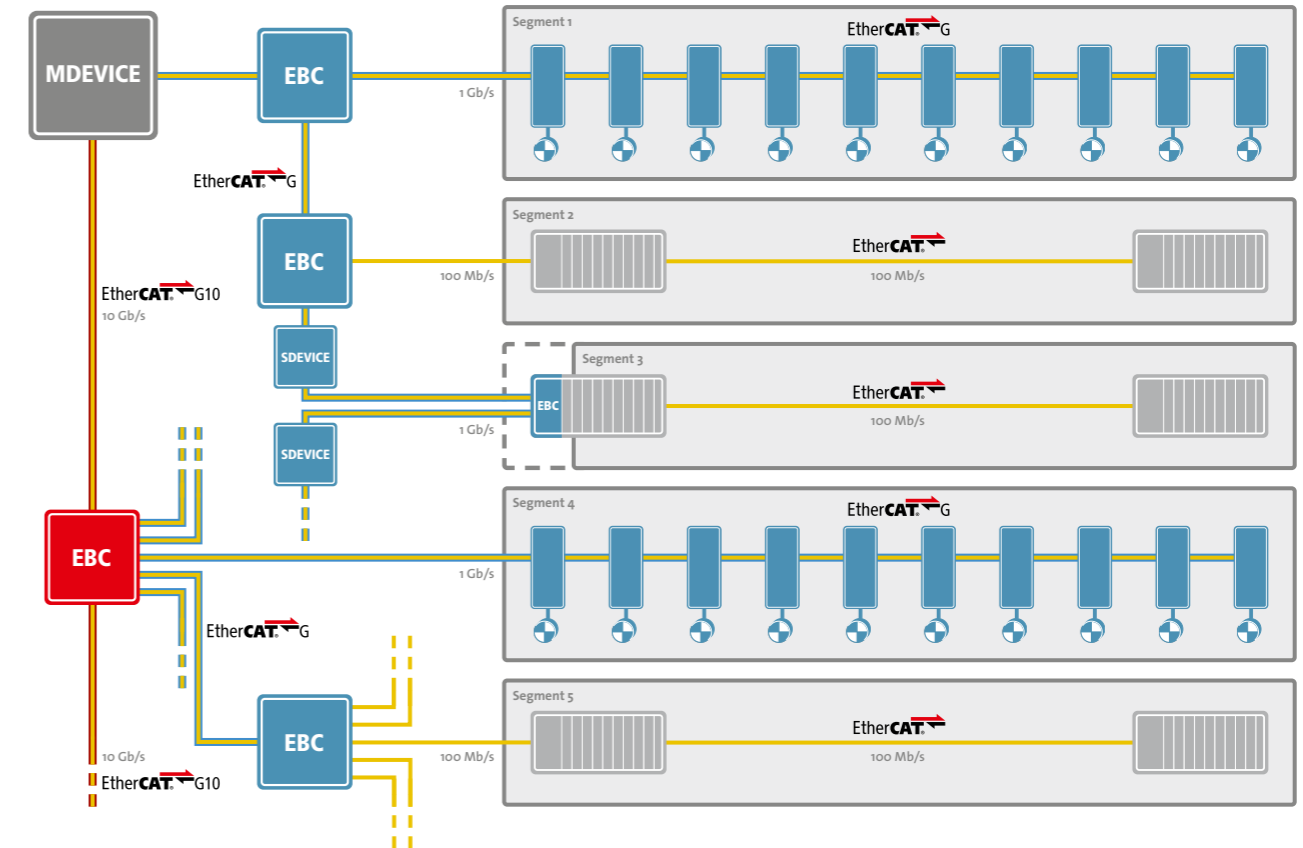

Example setup for an EtherCAT G/G10 network

Further information about EtherCAT G can be found here: www.ethercat.org/ethercat-g

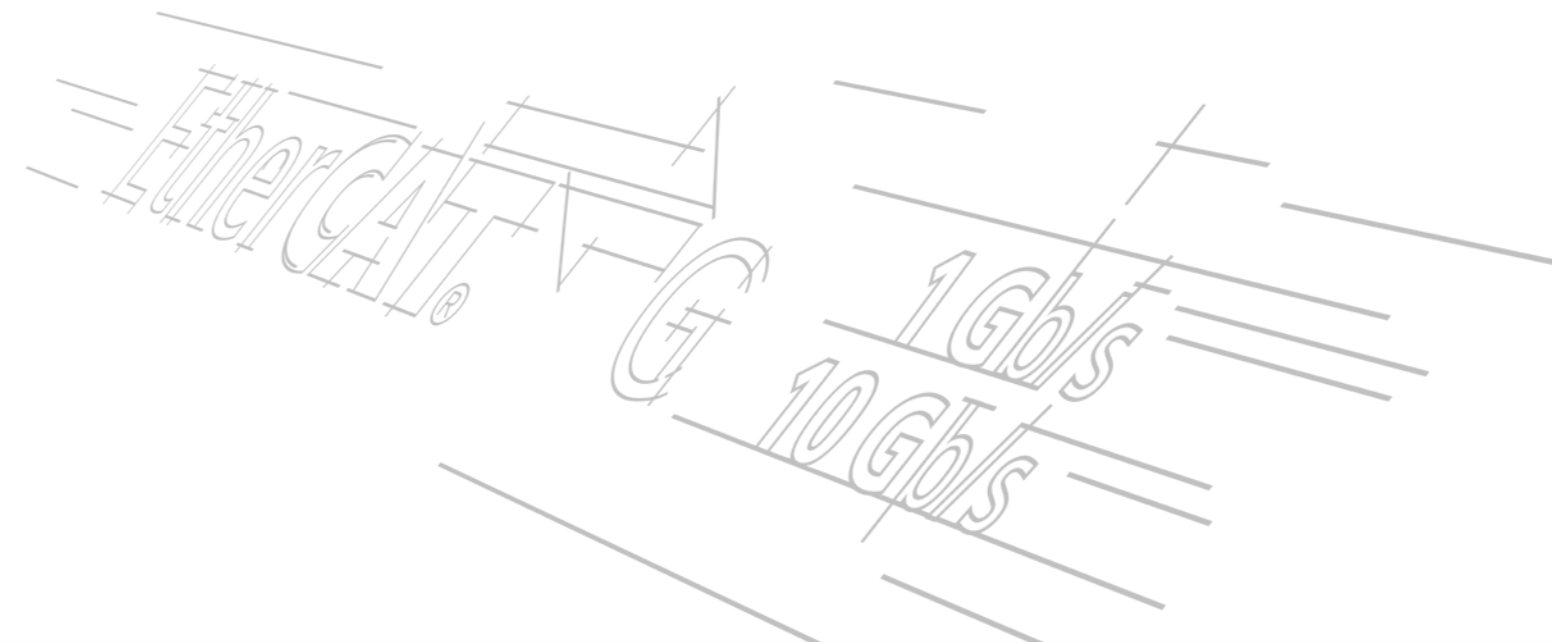

System overview

EtherCAT plant network

EtherCAT machine control network

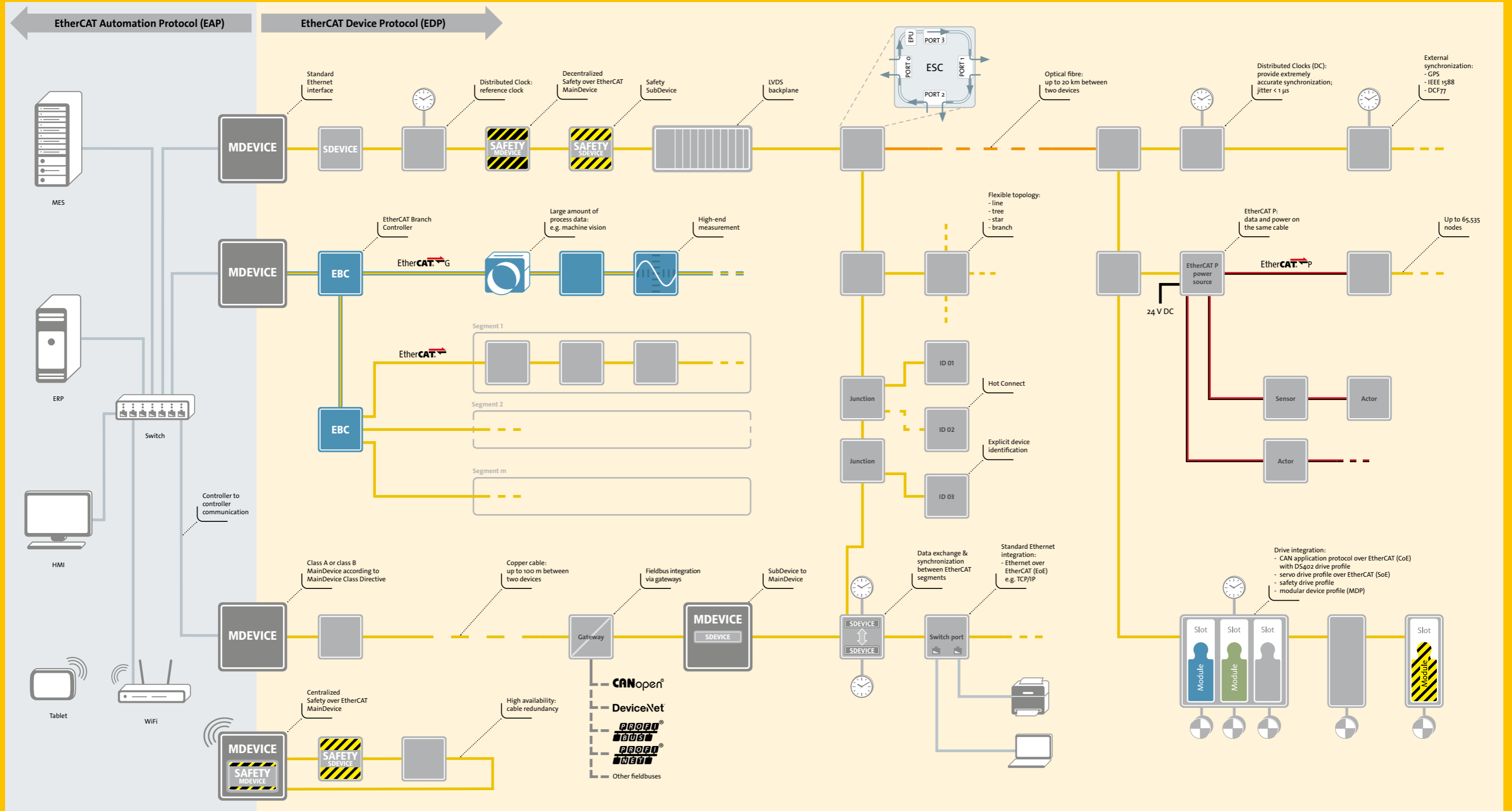

EtherCAT P: Communication and power in one cable

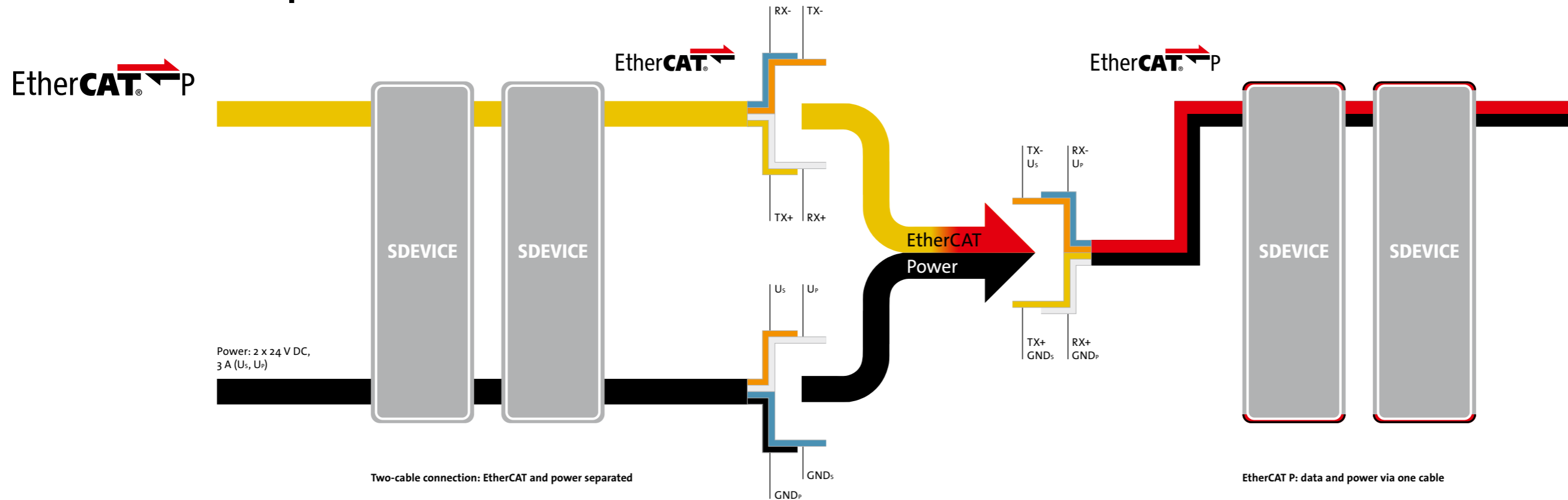

EtherCAT P (P = power) is an addition to the previously described EtherCAT protocol standard. It enables the transmission of both communication data and the peripheral voltage via a single, standard four-wire Ethernet cable.

EtherCAT and EtherCAT P are identical in terms of protocol technology, as the addition exclusively affects the physical layer. New EtherCAT SubDevice Controllers are not required for using EtherCAT P. EtherCAT P has the same communication advantages as EtherCAT, but also provides the power supply via the communication cable, offering attractive benefits and enhancements for numerous applications.

Two electrically isolated, individually switchable 24 V supplies power the EtherCAT P devices, available with U_s for the system and sensors and U_p for the periphery and actuators. Both voltages, U_s and U_p, are directly coupled to the 100 Mb/s EtherCAT communication line. Thanks to this power transmission, the user can cascade several EtherCAT P devices and therefore only needs one cable.

This facilitates reduced cabling, more compact, cost-effective wiring, lower system costs, and a smaller footprint for devices, equipment, and machines.

EtherCAT P is especially useful for the parts of a machine that are self-contained and often a bit isolated, as they can be supplied with data and power through a single stub cable. Sensors of all types are perfectly suitable for EtherCAT P: a single compact M8 connector enables efficient integration of these field devices into the high-speed network and connects them to the supply voltage. Potential error sources while connecting devices are avoided, thanks to mechanical coding of the connector.

EtherCAT P can be used in a network together with standard EtherCAT technology. Appropriate rectifier units transform common EtherCAT physics to EtherCAT P by consistently maintaining the Ethernet data encoding. In the same way, a device itself can be supplied with EtherCAT P and can also transmit.

Further information about EtherCAT P can be found here: www.ethercat.org/ethercat-p



Safety over EtherCAT



Modern communication systems not only transfer control data deterministically, they also enable the transfer of safety-critical control data through the same medium. EtherCAT utilizes the Safety over EtherCAT (FSoE = FailSafe over EtherCAT) protocol for this very purpose and so provides:

- a single communication system for both control and safety data
- the ability to flexibly modify and expand the safety system architecture
- pre-certified solutions for simplifying safety applications
- powerful diagnostic capabilities for safety functions
- seamless integration of the safety design in the machine design
- the ability to use the same development tools for both standard and safety applications

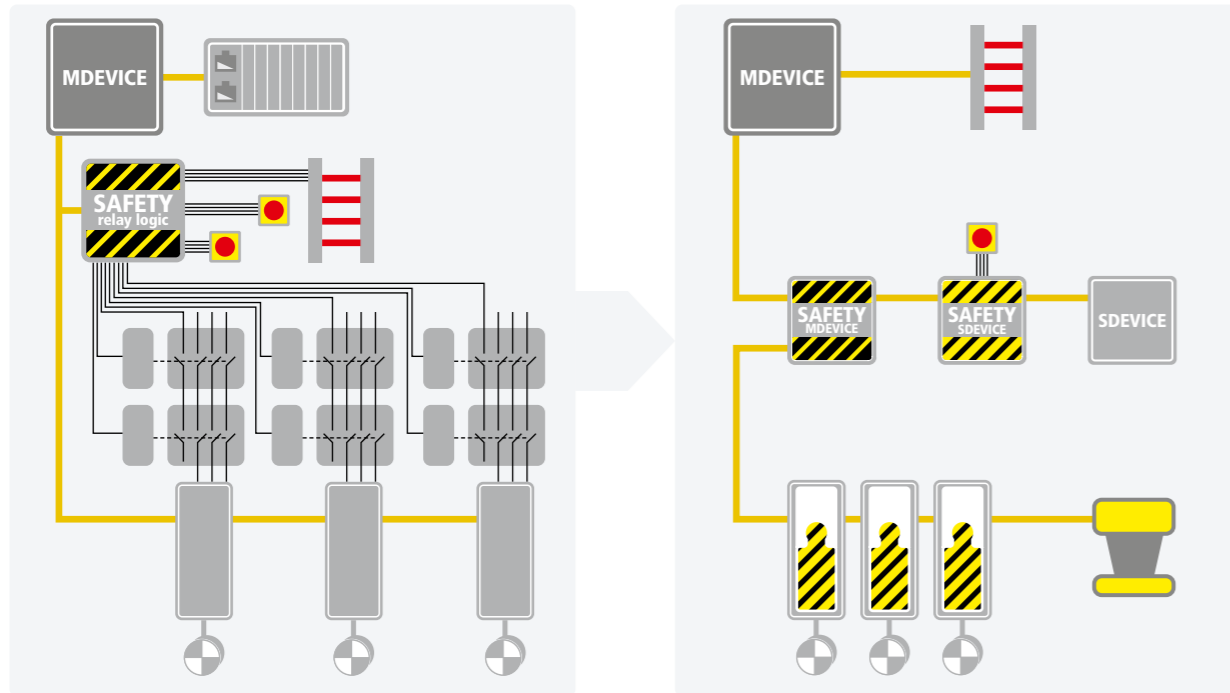

Safety over EtherCAT enables simpler and more flexible architectures than those achieved with relay logic.

The EtherCAT safety technology was developed according to IEC 61508, is approved by TÜV SÜD Rail, and is standardized in IEC 61784-3. The protocol is suitable for safety applications with a safety integrity level of up to SIL 3.

With Safety over EtherCAT, the communication system is part of a black channel, which is not considered to be safety-relevant. The EtherCAT standard communication system makes use of a single channel to transfer both standard and safety-critical data. Safety over EtherCAT frames, known as safety containers, contain safety-critical process data and

additional information used to secure this data. The safety containers are transported as part of the communication's process data. The safety of the data transfer does not depend on the underlying communication technology, and isn't restricted to EtherCAT; safety containers can travel through fieldbus systems, Ethernet or similar technologies, and can make use of copper cables, fiber optics, and even wireless connections.

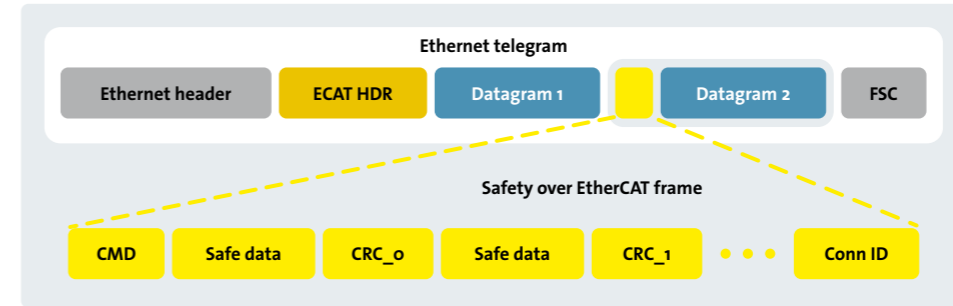

The Safety over EtherCAT frame (safety container) is embedded in the cyclical communication's process data.

Due to this flexibility, safely connecting different parts of the machine becomes more simple. The safety container is routed through the various controllers and processed in the various parts of the machine. This makes it easy to implement emergency stop functions for an entire machine or to bring targeted parts of a machine to a standstill – even if the parts of the machine are coupled with other communication systems (e.g. Ethernet).

Implementing the FSoE protocol in a device requires few resources and can lead to a high level of performance and result in short reaction times. In the robotics industry, for example, there are applications that use FSoE for safe motion control applications in an 8 kHz closed loop.

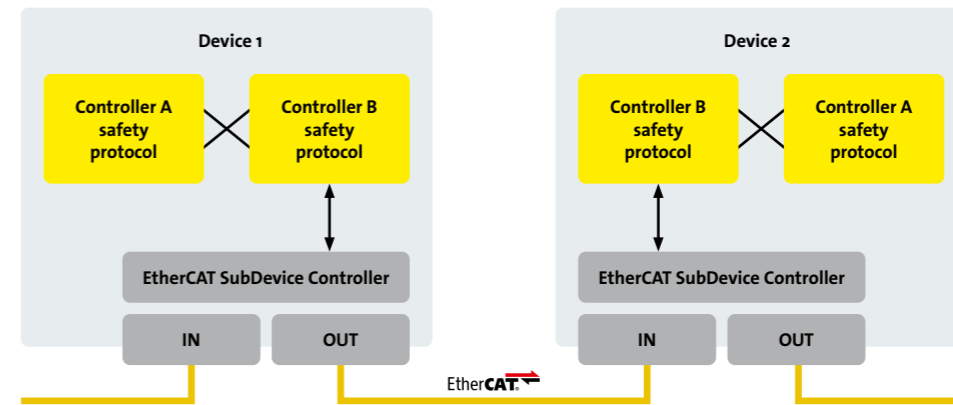

Black channel principle: the standard communication interface can be used.

Further information regarding Safety over EtherCAT can be found on the ETG website: www.ethercat.org/safety



Communication profiles

In order to configure and diagnose SubDevices, the variables provided for the network can be accessed with the help of acyclic communication. This is based on a reliable mailbox protocol with an auto-recover function for erroneous messages.

In order to support a wide variety of devices and application layers, the following EtherCAT communication profiles have been established:

- CAN application protocol over EtherCAT (CoE)
- servo drive profile according to IEC 61800-7-204 (SoE)
- Ethernet over EtherCAT (EoE)
- file access over EtherCAT (FoE)
- ADS over EtherCAT (AoE)

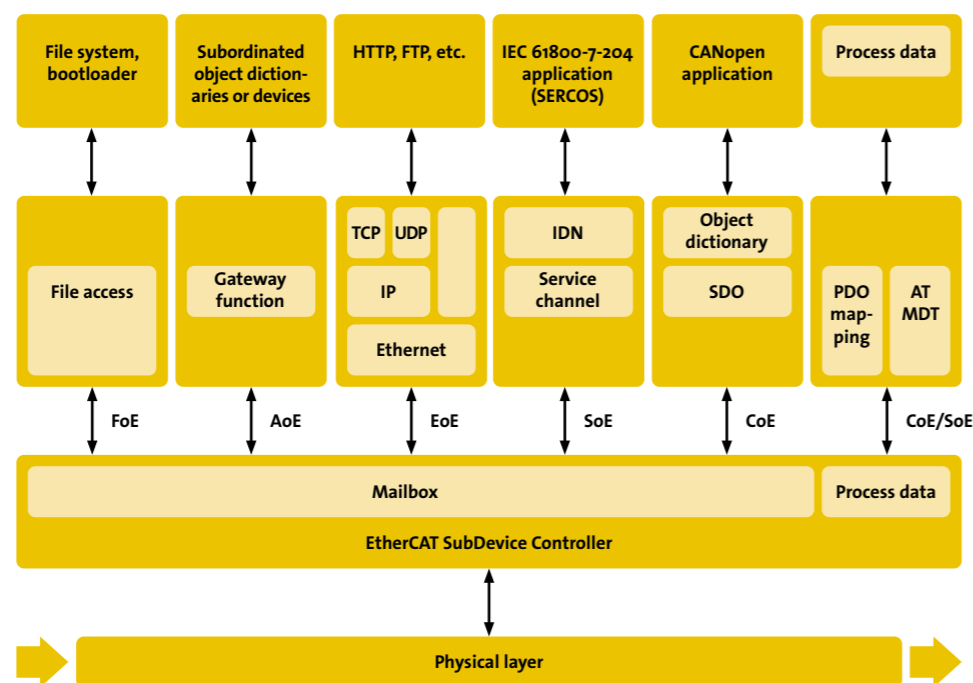

Different communication profiles can coexist in the same system.

A field device isn't required to support all communication profiles; instead, it may decide which profile is most suitable for its needs. The MainDevice is told which communication profiles have been implemented via the SubDevice description file.

CAN application protocol over EtherCAT (CoE)

With the CoE protocol, EtherCAT provides the same communication mechanisms as in CANopen® Standard EN 50325-4: object dictionary, mapping of process data objects (PDO) and service data objects (SDO). Even the network management is similar. This makes it possible to implement EtherCAT with minimal effort in devices that were previously outfitted with CANopen, and large portions of the CANopen firmware can even be reused. Optionally, the legacy 8-byte PDO limitation can be waived, and the enhanced bandwidth of EtherCAT can also be used to support the upload of the entire object dictionary. The device profiles, such as the CiA 402 drive profile, can also be reused for EtherCAT.

Servo drive profile according to IEC 61800-7-204 (SoE)

SERCOS™ is known as a real-time communication interface, especially for motion control applications. The SERCOS™ profile for servo drives is included in the international standard IEC 61800-7. The standard also contains the mapping of this profile to EtherCAT. The service channel, including access to all drive-internal parameters and functions, is mapped to the EtherCAT mailbox.

Ethernet over EtherCAT (EoE)

EtherCAT utilizes physical layers of Ethernet and the Ethernet frame. The term Ethernet is also frequently associated with data transfer in IT applications, which are based on a TCP/IP connection. Any Ethernet data traffic can be transported within an EtherCAT segment using the Ethernet over EtherCAT (EoE) protocol. Ethernet devices are connected

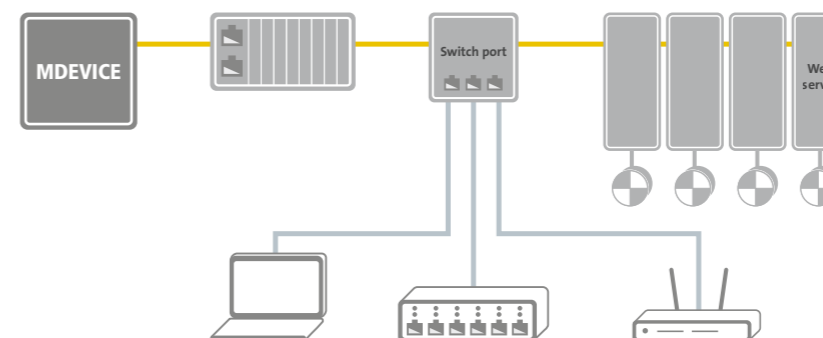

Transparent transmission of standard IT protocols

to an EtherCAT segment via switchports. The Ethernet frames are tunneled through the EtherCAT protocol, similar to the internet protocols (e.g. TCP/IP, VPN, PPPoE (DSL), etc.), which makes the EtherCAT network completely transparent for Ethernet devices. The device with the switchport property inserts TCP/IP fragments into the EtherCAT traffic and therefore prevents the network's real-time properties from being affected.

Additionally, EtherCAT devices may also support Ethernet protocols (such as HTTP) and can therefore behave like a standard Ethernet node outside of the EtherCAT segment. The control device acts as a layer 2 switch that sends the frames to the corresponding nodes via EoE according to their MAC addresses. All Internet technologies can thus also be implemented in an EtherCAT environment, such as an integrated web server, e-mail, FTP transfer, etc.

File access over EtherCAT (FoE)

This simple protocol similar to TFTP (Trivial File Transfer Protocol) enables file access in a device and a uniform firmware upload to devices across a network. The protocol is lean and does not require much software to implement, so that it can be supported by boot loader programs. A TCP/IP stack isn't required.

ADS over EtherCAT (AoE)

As a mailbox-based client-server protocol, ADS over EtherCAT (AoE) is defined by the EtherCAT specification. While protocols such as CAN application protocol over EtherCAT (CoE) provide a detailed semantic concept, AoE complements these perfectly via routable and parallel services wherever use cases require such features. For example, this might include access to sub-networks through EtherCAT using gateway devices from a PLC program such as CANopen®, IO-Link™, and others.

AoE comes with far less overhead compared to similar services provided by the Internet Protocol (IP). Both sender and receiver addressing parameters are always contained in the AoE datagram. As a result, implementation on both ends (client and server) can be very lean. AoE is also the protocol of choice for acyclic communication via the EtherCAT Automation Protocol (EAP) and therefore provides seamless communication between an MES system, the EtherCAT MainDevice, and subordinated fieldbus devices connected via gateways. AoE serves as the standard medium for obtaining EtherCAT network diagnostic information from a remote diagnostics tool.

Plant-wide communication with the EtherCAT Automation Protocol (EAP)

The process control level has special communication requirements that differ slightly from the requirements addressed by the EtherCAT Device Protocol, described in the previous sections. Machines or sections of a machine often need to exchange status information and information on the following manufacturing steps with each other. There is also usually a central controller that monitors the entire manufacturing process, thus providing the user with status information on productivity, and assigning orders to the various machine stations.

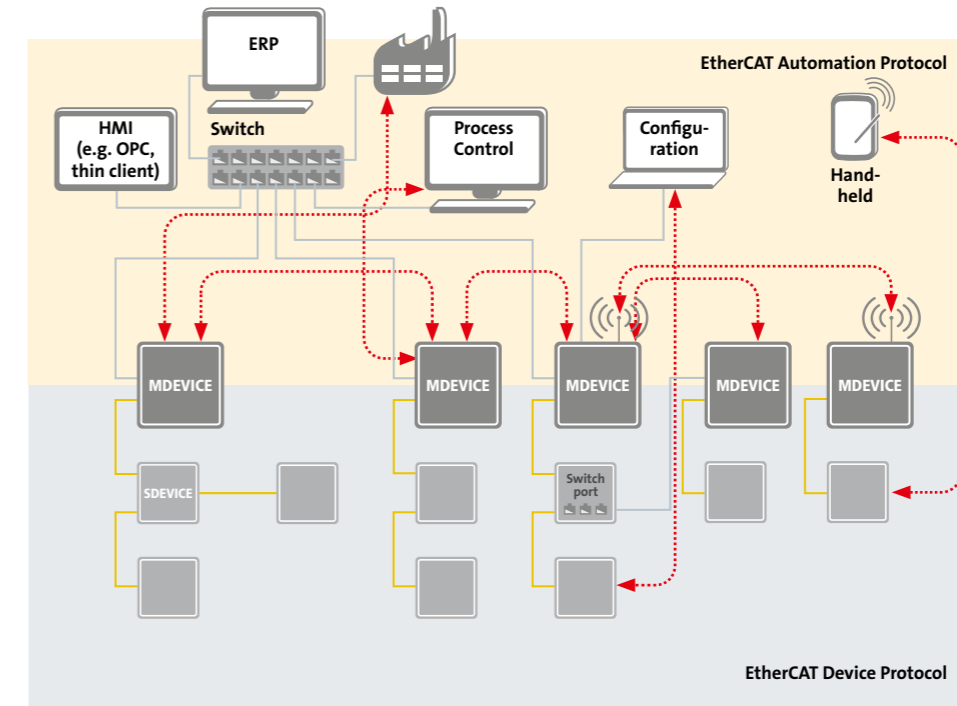

Factory-wide communication with EtherCAT

The EtherCAT Automation Protocol (EAP) fulfills all of the above requirements.

The protocol defines interfaces and services for:

- exchanging data between EtherCAT MainDevices (MainDevice-to-MainDevice communication)
- communication to human machine interfaces (HMI)
- a supervising controller to access devices belonging to underlying EtherCAT segments (routing),
- integration of tools for machine or plant configuration, and for device configuration.

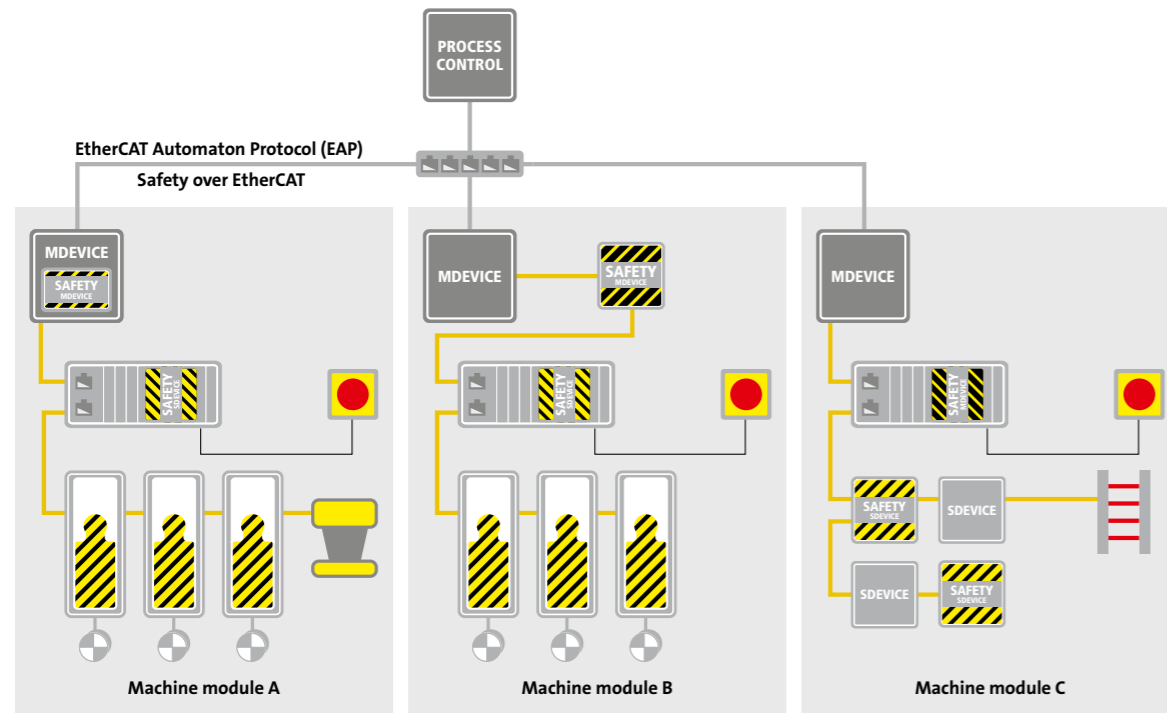

Factory-wide communication architecture with the EtherCAT Automation Protocol and Safety over EtherCAT

The communication protocols used in the EAP are part of the international standard IEC 61158. EAP can be transmitted via any Ethernet connection, including a wireless link, making it possible to include automated guided vehicles (AGV), for example, which are common in the semiconductor and automotive industries.

Cyclic process data exchange with EAP follows either the push or poll principle. In push mode, each node sends its data either with its own cycle time or in a multiple of its own cycle time. Each receiver can be configured to receive data from specific senders. Configuring the sender and receiver data is done through the familiar object dictionary. In poll mode, a node (often the central controller) sends a frame to the other nodes, and each node responds with its own frame.

The cyclic EAP communication can be directly embedded in the Ethernet frame without additional transport or a routing protocol. Again, the EtherType 0x88A4 identifies the EtherCAT-specific use of the frame. This enables the exchange of high-performance data with EAP in a millisecond cycle. If data routing between distributed machines is required, the process data can also be transmitted via UDP/IP or TCP/IP.

Additionally, with the help of the Safety over EtherCAT protocol, safety-critical data can also be transmitted via EAP. This is common in cases where parts of a large machine need to exchange safety-critical data to execute a global emergency stop function, or to inform neighboring machines of an emergency stop.

Integration of other bus systems

EtherCAT's ample bandwidth allows conventional fieldbus networks to be embedded as underlying systems via an EtherCAT gateway, which is particularly helpful when migrating from a conventional fieldbus to EtherCAT. The changeover to EtherCAT is gradual, making it possible to continue using automation components that don't yet support an EtherCAT interface.

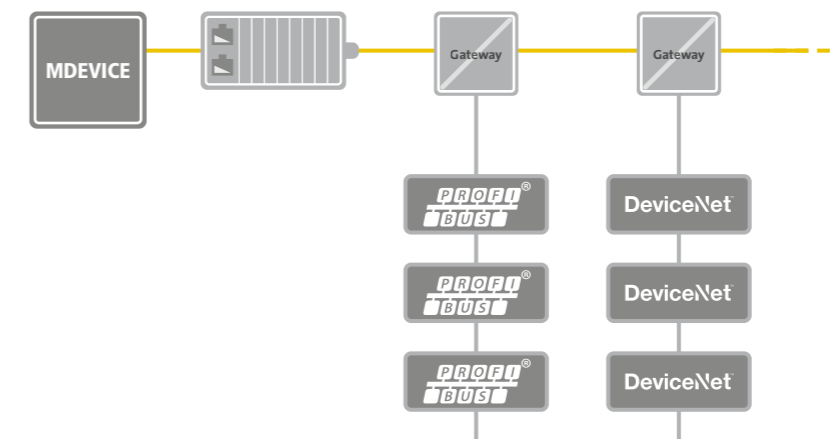

EtherCAT enables the integration of decentralized fieldbus interfaces

The ability to integrate decentralized gateways also reduces the physical size of the industrial PC, sometimes even to an embedded industrial PC, since extension slots are no longer necessary. In the past, extension slots were also required to connect complex devices, such as fieldbus MainDevice and SubDevice gateways, fast serial interfaces, and other communication subsystems. In EtherCAT, only a single Ethernet port is needed to connect these devices. The process data from the underlying subsystem is made directly available in the process image of the EtherCAT system.

Powering the digital transformation with EtherCAT, Industry 4.0 and IoT



Process optimizations, predictive maintenance, manufacturing as a service, adaptive systems, resource-savings, smart factories, cost reductions: there are countless good reasons to utilize control network data in higher level systems.

The Internet of Things (IoT), Industry 4.0, Made in China 2025, Industrial Value Chain Initiative – there is a common demand across the board for seamless, continuous and standardized communication across all levels. Sensor data is uploaded into the cloud along with recipes and parameters downloaded from ERP systems into distributed devices; take, for example, a feeding system shared by two machines: there are requirements on the data flow both horizontally and vertically.

EtherCAT is inherently equipped to deal with digital transformation through its high performance, flexibility, and open interfaces:

- Superior system performance is a prerequisite for adding big data features to control networks.
- EtherCAT provides the flexibility to add cloud connectivity to existing systems without even touching the controller or updating the field devices: edge gateway can access any data within any EtherCAT field device via the mailbox gateway feature of the EtherCAT MainDevice. The edge gateway can either be a remote device and talk to the MainDevice via TCP or UDP/IP, or a software entity directly located on the same hardware as the EtherCAT MainDevice itself.
- Additionally, open interfaces mean that any IT-based protocol can be integrated – including OPC UA, MQTT, AMQP or any others – either within the MainDevice or directly into the connected devices, thus providing a direct link for IoT without protocol discontinuities from the sensor to the cloud.

All these features have always been part of the EtherCAT protocol, which shows how forward-thinking the architecture is. Nevertheless, more networking features are added as they evolve and become relevant. Of course, it is also important to consider the past when looking forward: introduction of valuable new features is managed with total network continuity. The EtherCAT protocol has been stable at “Version 1” since it was released in 2003.

Other new developments in Time-Sensitive Networking (TSN) features further improve the real-time capabilities of controller-to-controller communication. Enabled by TSN, control systems can access a network of EtherCAT devices across plant networks, too. Since EtherCAT typically only needs one frame for an entire network, access is much leaner and thus faster than any other fieldbus or industrial Ethernet technology. In fact, EtherCAT Technology Group experts have contributed to the TSN task group of IEEE 802.1 from day one, back when TSN was still known as AVB (Audio Video Bridging).

Further information about EtherCAT and TSN can be found here: www.ethercat.org/tsn

The EtherCAT Technology Group (ETG) was also among the first fieldbus organizations to partner with the OPC Foundation. The OPC UA protocol complements the EtherCAT portfolio because it is a scalable TCP/IP based client/server communication technology with integrated security, enabling encrypted data transfer in MES/ERP systems.

With OPC UA Pub/Sub, the usability of OPC UA has been improved in machine-to-machine (M2M) applications and for vertical communication to cloud-based services. The ETG is actively contributing to all these developments to ensure that they fit seamlessly into the EtherCAT environment. EtherCAT is not only IoT-ready, EtherCAT is IoT!

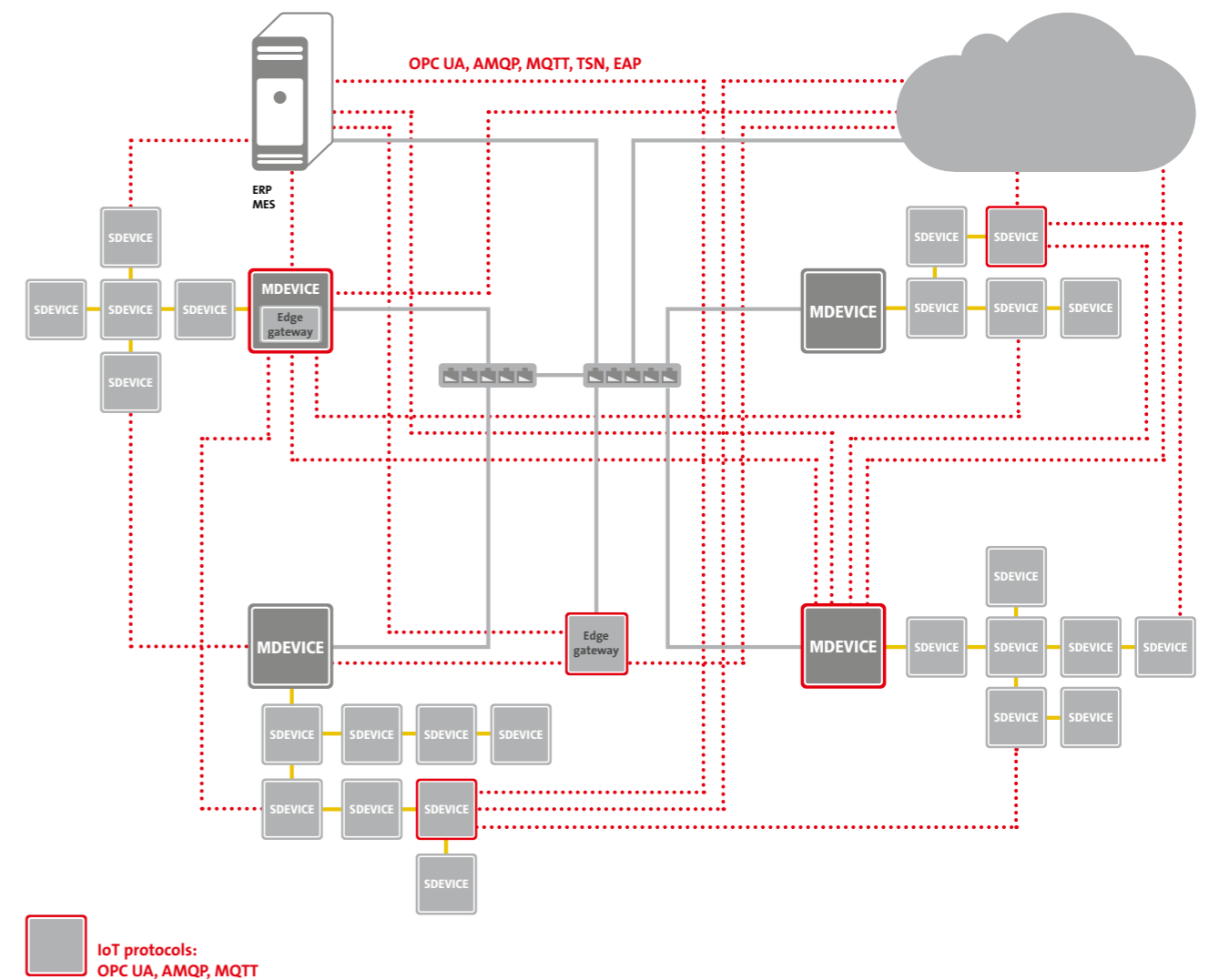



Implementing EtherCAT interfaces

EtherCAT technology has been specially optimized to enable low-cost design, so adding an EtherCAT interface to a sensor, I/O device, or embedded controller should not significantly increase device costs. Furthermore, the EtherCAT interface doesn't require a more powerful CPU; the CPU requirements are solely based on the needs of the target application.

In addition to hardware and software requirements, development support and availability of the communication stacks are important factors when developing an interface. The EtherCAT Technology Group offers worldwide developer support as it answers questions and addresses technical issues quickly. Finally, evaluation kits available from multiple manufacturers, developer workshops, and free sample code make getting started a little easier.

For the end user, the most important factor is the interoperability of EtherCAT devices from various manufacturers. To assure interoperability, device manufacturers are required to perform a conformance test before they bring their device on to the market. The test checks if the implementation follows the EtherCAT specification, and can be performed with the EtherCAT Conformance Test Tool. The test can also be used during device development to discover and correct implementation issues early on.

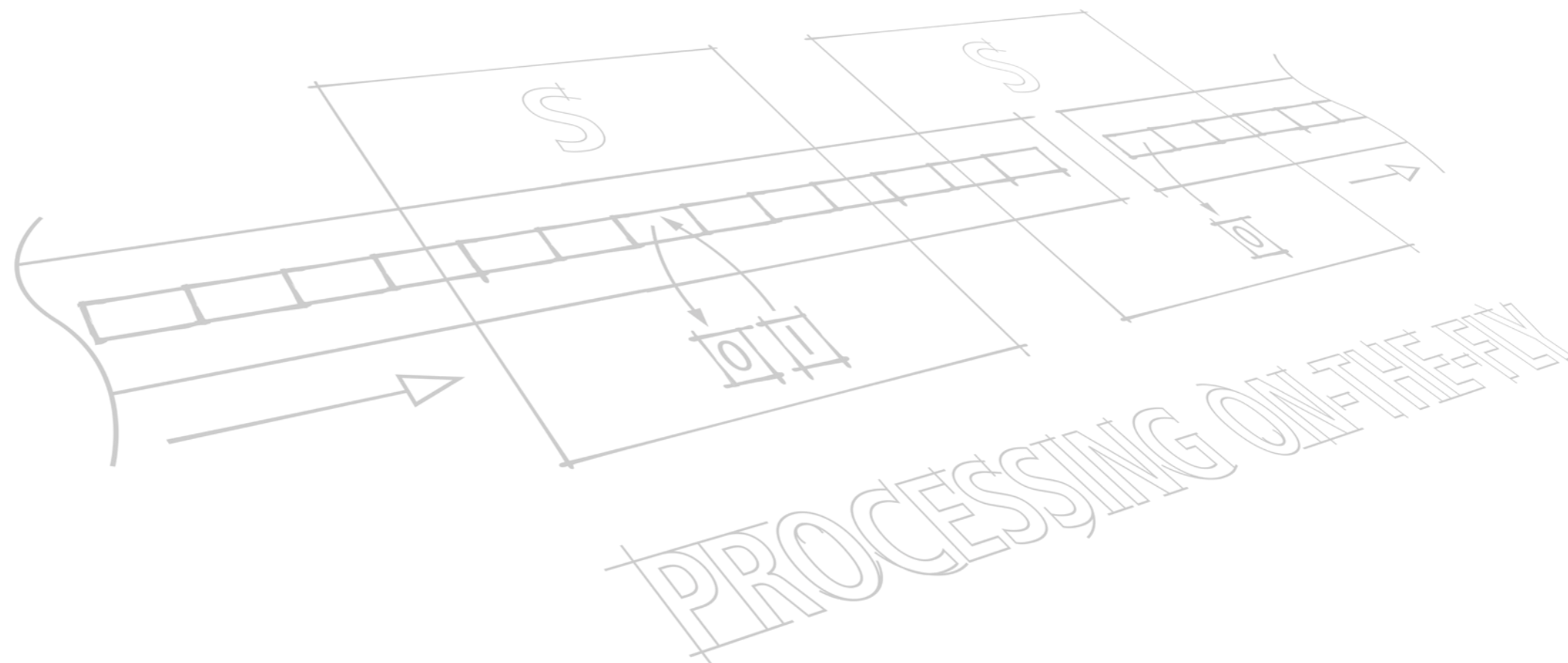

Implementing a MainDevice



The interface for an EtherCAT MainDevice (MDevice) has a sole, unbelievably simple, hardware requirement: an Ethernet port. The implementation uses either the on-board Ethernet controller or an inexpensive standard network card, so no special interface card is required. That means that with just a standard Ethernet port, a MainDevice can implement a hard real-time network solution.

In most cases, the Ethernet controller is integrated via direct memory access (DMA), so no CPU capacity is required for the data transfer between the MainDevice and the network. In an EtherCAT network, mapping occurs in the connected field devices. Each device writes its data to the right location in the process image and reads the data addressed to it all while the frame is moving through the device. The process image that arrives at the MainDevice has already been sorted correctly.

Since the MainDevice CPU is no longer responsible for the sorting, its performance requirements depend solely on the desired application and not on the EtherCAT interface. Implementing an EtherCAT MainDevice is a snap, especially for small, mid-range, and clearly defined applications. EtherCAT MainDevices have been implemented for a wide variety of operating systems: Windows and Linux in various iterations, QNX, RTX, VxWorks, INtime, eCos are just a few examples.

ETG members offer a variety of options that support the implementation of an EtherCAT MainDevice, ranging from free downloads of EtherCAT MainDevice libraries and sample MainDevice code to complete packages (including services) for various real-time operating systems and CPUs.

In order to operate a network, the EtherCAT MainDevice needs the cyclic process data structure as well as boot-up commands for each field device. These commands can be exported to an EtherCAT Network Information (ENI) file with the help of an EtherCAT configuration tool, which uses the EtherCAT SubDevice Information (ESI) files from the connected devices.

The breadth of available MainDevice implementations and their supported functions varies. Depending on the target application, optional functions are either supported or deliberately omitted to optimize the utilization of hardware and software resources. For this reason, EtherCAT MainDevices are categorized into two classes: a class A MainDevice is a standard EtherCAT MainDevice, while a class B MainDevice is a MainDevice with fewer functions. In principle, all MainDevice implementations should aim for class A classification. Class B is only recommended for cases in which the available resources are insufficient to support all functionalities, such as in embedded systems.

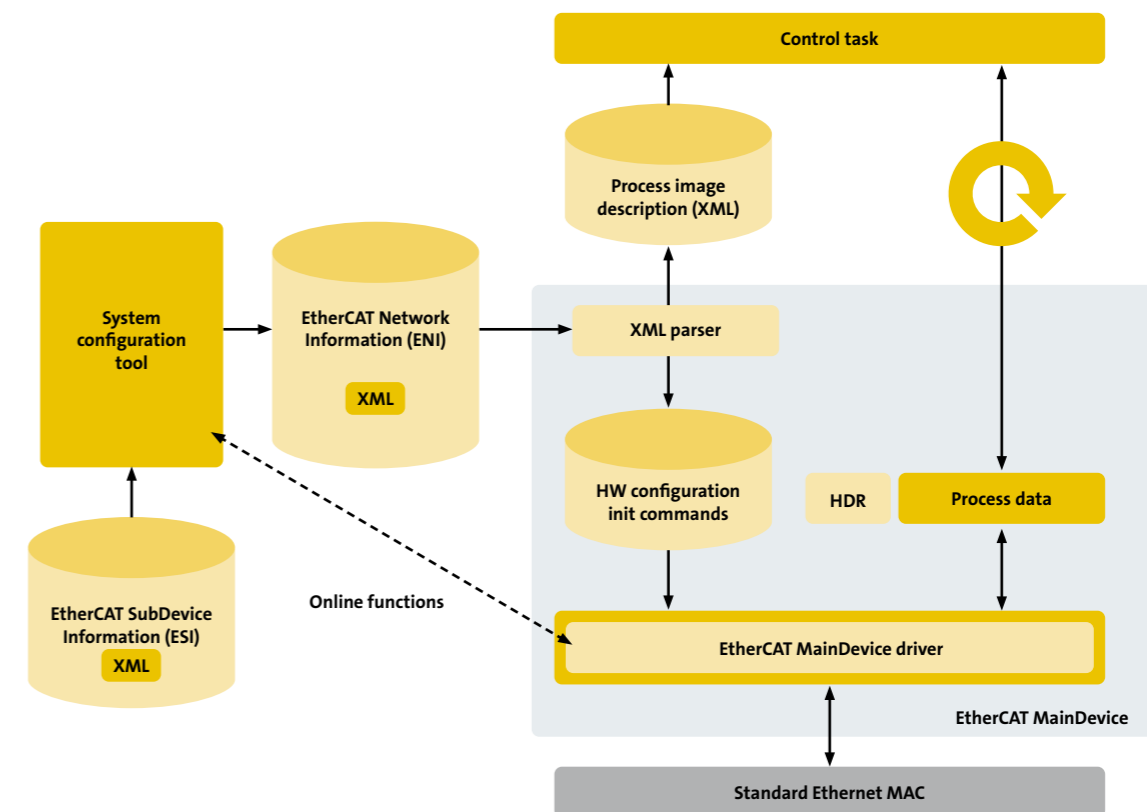

Typical EtherCAT MainDevice architecture

Implementing a SubDevice

EtherCAT field devices use inexpensive EtherCAT SubDevice Controllers (ESC) in the form of an ASIC, FPGA, or integrated in a standard microcontroller. Simple field devices don't even need an additional microcontroller, because inputs and outputs can be directly connected to the ESC. For more complex devices, the communication performance only minimally depends on the microcontroller performance, and in most cases, an 8-bit microcontroller is sufficient.

EtherCAT SubDevice Controllers are available from multiple manufacturers, with the size of the internal DPRAM and the number of Fieldbus Memory Management Units (FMMUs) varies depending on the type. Different process data interfaces (PDI) are available so that the application controller can gain external access to the application memory.

- The 32-bit parallel I/O interface is suitable for connecting up to 32 digital inputs and outputs, but also for simple sensors or actuators for which 32 data bits are sufficient and no application controller is required.
- The Serial Peripheral Interface (SPI) is targeted at applications with small amounts of process data, such as analog I/O devices, encoders, or simple drives.
- The parallel 8/16-bit microcontroller interface corresponds to common interfaces of fieldbus controllers with integrated DPRAM. It is particularly well-suited to complex nodes with larger amounts of data.
- Suitable synchronous buses for various microcontrollers are provided for FPGA and system-on-chip (SoC) implementations.

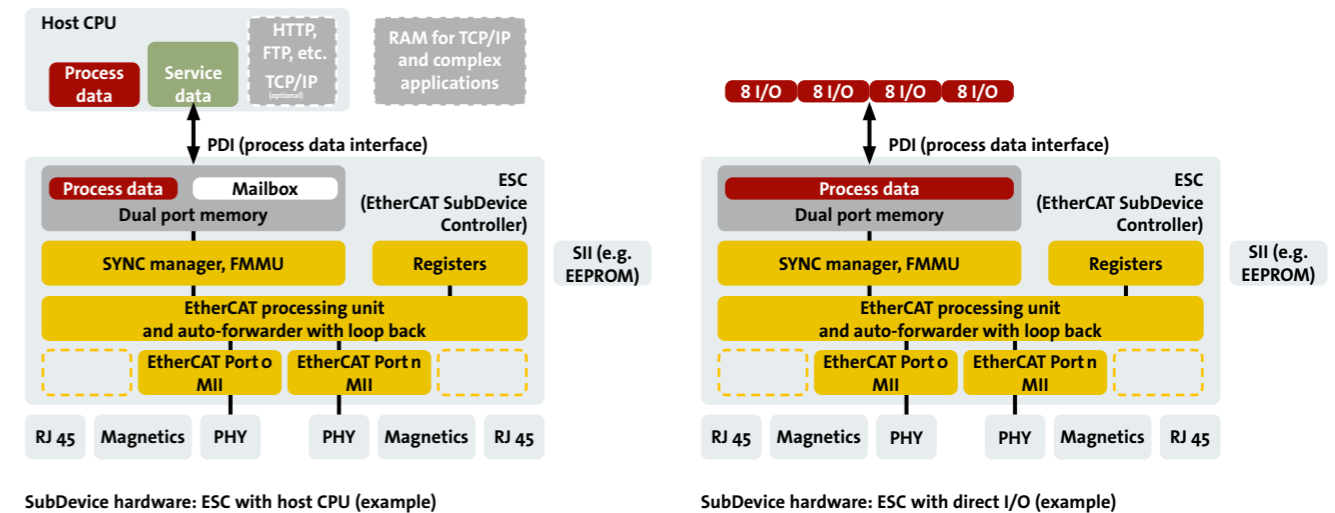

The hardware configuration is stored in a non-volatile memory (e.g. an EEPROM). In addition, this SubDevice Information Interface (SII) contains information on the main device features so that the MainDevice can read this at boot-up and operate the device even if the device description file is not available. The EtherCAT SubDevice Information (ESI) file that comes with the device is XML based and contains the complete description of its network accessible properties, such as process data and mapping options for it, the supported mailbox protocols including optional features, as well as the supported modes of synchronization. An EtherCAT network configuration tool uses this information for online and offline configuration of the network.

Various manufacturers offer evaluation kits for implementing SubDevices. These kits include SubDevice application software in source code, and they sometimes also include a test MainDevice. With an evaluation kit, a fully functional MainDevice-SubDevice EtherCAT network can be commissioned in just a few steps.

The ETG website contains the ETG.2200 SubDevice Implementation Guide with useful tips and recommendations for further documentation for implementing field devices:

www.ethercat.org/etg2200

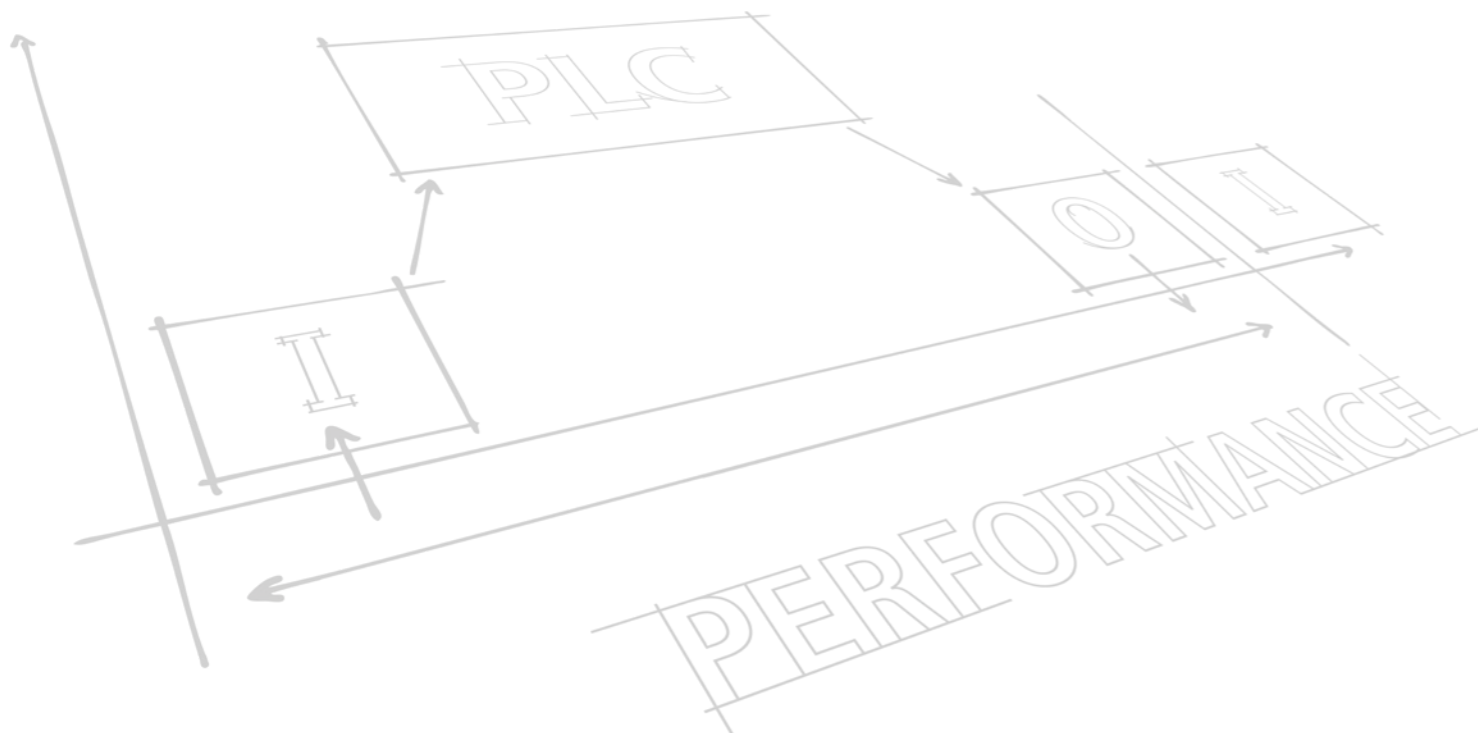



Two of the most important factors for creating a successful communication standard are conformance and interoperability, and the EtherCAT Technology Group takes both of these factors very seriously. In addition to requiring a conformance test for each instance of device implementation (aided by the automated EtherCAT Conformance Test Tool), the ETG undertakes a wide variety of activities to ensure interoperability between EtherCAT MainDevices, field devices, and EtherCAT configuration tools.

EtherCAT Plug Fest

When we test whether multiple devices are interoperable, one of the most pragmatic things to do is to try connecting the devices together. With this approach in mind, the ETG holds multiple EtherCAT Plug Fests each year, with each one usually spanning two days. During these events, MainDevice and field device manufacturers meet to test how their devices behave together, which improves the usability of devices in the field. Members can exchange EtherCAT tips and tricks and have their questions answered by EtherCAT experts. The ETG holds EtherCAT Plug Fests in Europe, North America, and Asia.

EtherCAT Conformance Test Tool

The EtherCAT Conformance Test Tool (CTT) enables an EtherCAT field device's behavior to be tested automatically.

It's a Windows program that only requires a standard Ethernet port. The tool sends EtherCAT frames to the device under test (DuT) and receives responses from it. A test case is marked as passed if the response from the DuT corresponds to the defined response. The test cases are defined as XML files. This means that the test cases can be modified or expanded without having to modify the actual test tool. The Technical Working Group Conformance is responsible for specifying and releasing the latest valid test cases.

In addition to the protocol tests, the CTT also examines whether the values in the EtherCAT SubDevice Information (ESI) file are valid. Finally, the CTT performs device-specific protocol tests, such as for the CiA 402 drive profile.

All of the testing steps and results are saved in a test logger, and can be analyzed or saved as a documented verification for the device release.

The ETG consistently maintains and adds new test cases to the CTT. It is important that a device manufacturer always has the most recent version of the tool for testing products prior to release. To make this easier, the CTT is offered as a subscription. The CTT is also useful for uncovering early errors in the interface implementation during the design phase.

Technical Working Group Conformance

The EtherCAT Conformance Test Policy requires device manufacturers to test each device with a valid version of the EtherCAT Conformance Test Tool before the device is brought onto the market. The manufacturer may conduct this test in-house.

The ETG Technical Committee (TC) established a Technical Working Group (TWG) for Conformance, which determines the test procedures, the contents of the test, and the implementation of the Conformance Test Tool. The TWG Conformance continuously expands the tests and their depth.

The TWG Conformance also established an interoperability test process, which can be used to test devices in the context of an entire network.

EtherCAT Test Center

The official EtherCAT Test Centers (ETC) in Europe, Asia, and North America are accredited by the ETG and perform the official EtherCAT Conformance Test. The EtherCAT Conformance Test includes the automated tests run with the CTT, interoperability tests within a network, and an examination of the device's indicators, markings, and tests of the EtherCAT interfaces.

Device manufacturers are encouraged but not obligated to have their devices tested at an ETC. After the conformance test has been passed, the manufacturer receives an EtherCAT Conformance Tested certificate for the device. This certificate is only issued for devices that have passed the official conformance test at an ETC, and not for those which have been tested in-house.

The additional test in an accredited EtherCAT Test Center further increases compatibility and aids uniform operation and diagnostics of EtherCAT implementations. End users should be sure to ask for the EtherCAT Conformance Tested certificate when choosing devices for their application.

In addition to the EtherCAT Conformance Test, there's another conformance test which has been developed especially for devices with a safety interface and which is mandatory for manufacturers of FSoE devices according to the FSoE policy. The test is conducted by an official notified body and provides solid confirmation of reliable and standard compliant implementation of the Safety over EtherCAT protocol.

More information on conformance and certification is available on the ETG website:
www.ethercat.org/conformance

www.ethercat.org

The EtherCAT website provides comprehensive information about the technology as well as upcoming events, the latest EtherCAT products, and the current membership directory. It also covers special topics such as functional safety and conformance of EtherCAT devices. You can find out about the benefits of free membership, download presentations, press articles, and publications at www.ethercat.org/downloads.

EtherCAT Product Guide

The EtherCAT Product Guide is a directory listing a selection of EtherCAT products and services based on information provided by ETG members, and is available online at www.ethercat.org/products. If you have any questions about the products, please contact the manufacturer directly, as the ETG itself does not sell any products.

Events

The event section shows the events hosted by the ETG worldwide and those that are organized in conjunction with the association. www.ethercat.org/events is a calendar where all the important dates can be found, including those for the technical working group meetings, exhibition appearances, EtherCAT workshops, and Industrial Ethernet seminars.

Member Area

Members have insider access to the protected area of the website at www.ethercat.org/memberarea, which contains valuable additional items such as all EtherCAT specifications, the online developer forum, and a knowledge base containing with all necessary information for implementation, configuration and diagnosis of EtherCAT devices and networks.

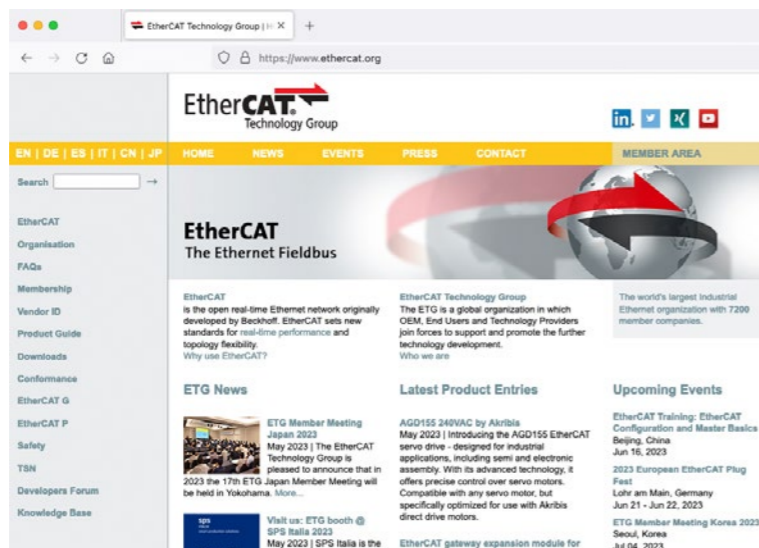

ETG worldwide



Contact

ETG Headquarters
Ostendstraße 196
90482 Nuremberg
Germany
+ 49 (911) 5 40 56 20
info@ethercat.org

ETG Office North America
San Jose, CA, USA
+1 (877) ETHERCAT
info.na@ethercat.org

ETG Office China
Beijing, China
+ 86 (10) 8220 0090
info@ethercat.org.cn

ETG Office Japan
Yokohama, Japan
+ 81 (45) 650 1610
info.jp@ethercat.org

ETG Office Korea
Seoul, Korea
+82 (0)2 2107 3242
info.kr@ethercat.org

Technical support

ETG Headquarters
Ostendstraße 196
90482 Nuremberg
Germany
+ 49 (911) 5 40 56 222
techinfo@ethercat.org

EtherCAT®, EtherCAT G®, EtherCAT P®, and Safety over EtherCAT® are registered trademarks and patented technologies licensed by Beckhoff Automation GmbH, Germany. Other designations used in this publication may be trademarks which, when used by third parties for their own purposes, could violate the rights of the owners.